

Flat moon suspension 450 down LED

133000XX_133001XX_133002XX_133003XX_133004XX_133005XX

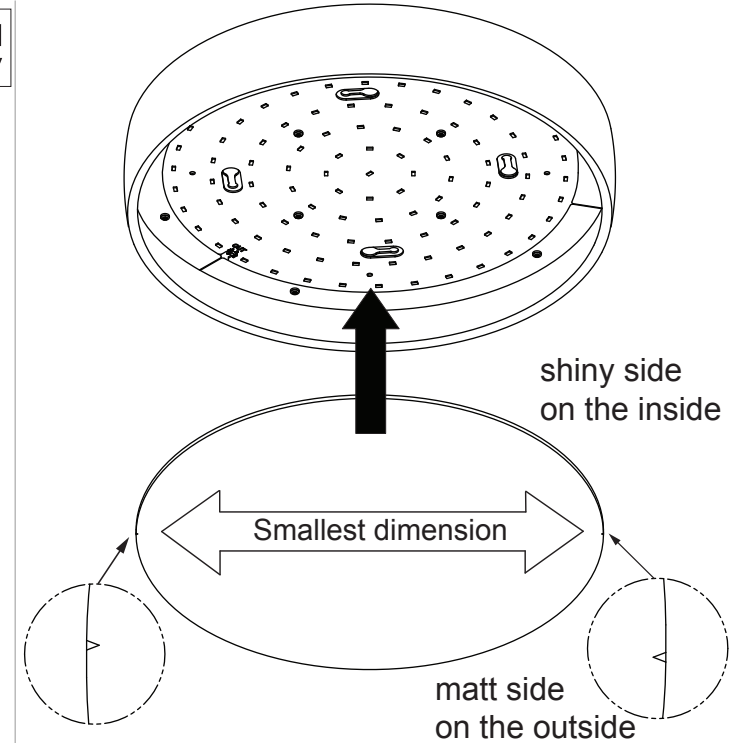

Replace protective shield when broken. The luminaire shall only be used complete with its protective shield. Reference number: 1012134

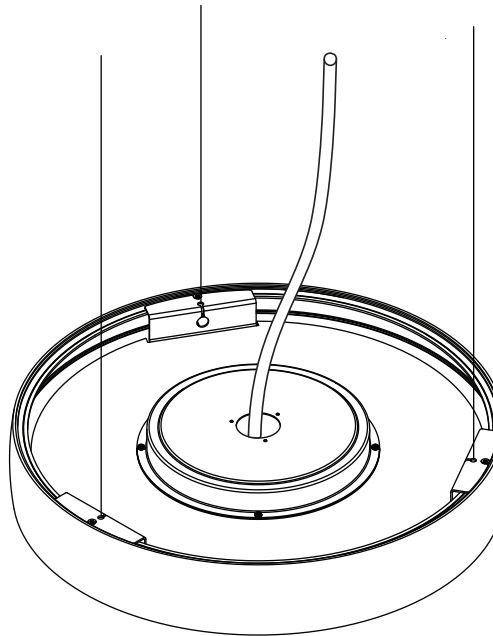
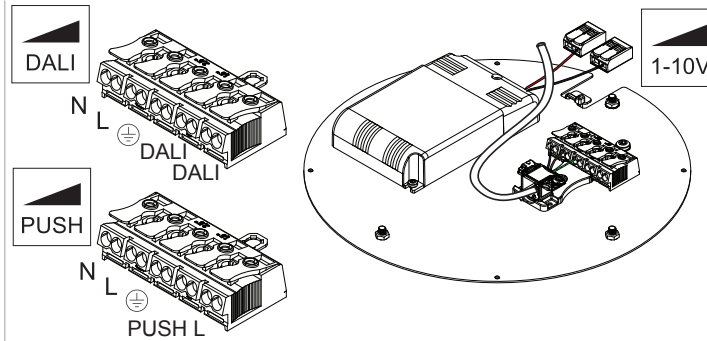
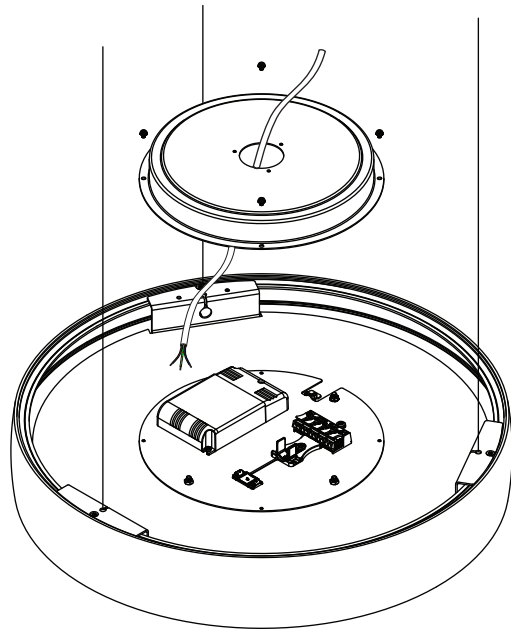
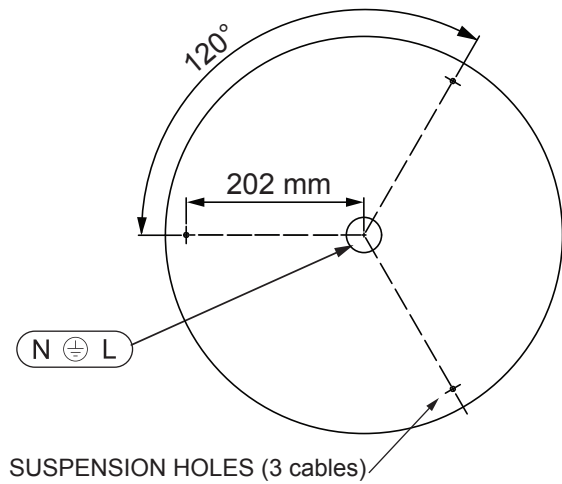

The light source contained in this luminaire shall only be replaced by the manufacturer or his service agent or a similar qualified person

CAN BE USED WITH

Susp kit non dimmable

11061809 Suspension kit 4m 3x0.75 (3 cables) - WhStr

11061832 Suspension kit 4m 3x0,75 (3 cables) BISt

11062009 Susp kit 1 4m 3x0,75 3tri cables WhStr

11062032 Susp kit 1 4m 3x0,75 3tri cables BISt

Susp kit dimmable

11061909 Suspension kit 4m 5x0,75 (3cables) Whstr

11061932 Suspension kit 4m 5x0,75 (3cables) BIstr

11062109 Susp kit 1 4m 5x0,75 3tri cables WhStr

11062132 Susp kit 1 4m 5x0,75 3tri cables BISt

Coverplate & Prismatic Diffuser

13309009 Flat moon 450 LED coverplate WhStr

13309032 Flat moon 450 LED coverplate BISt

13289000 FlatMn prismatic diffuser 450/470

13289100 FlatMn ice prismatic diffuser 450/470

