

January 2026



REWIRING INSTRUCTION



For luminaires to AC mains direct wiring for operation with LEDVANCE LED TUBE T8 EM, UNIVERSAL, T5 AC or DULUX LED lamps

Rewiring of 1-lamp Luminaires

The conversion of a luminaire to operation of LED tubes on AC mains directly can be of advantage in the following cases:

- The existing driver is broken or has reached the end of its nominal lifetime. Driver maintenance will then not be necessary anymore.
- The existing electronic driver is not compatible with the selected LEDVANCE LED Tube.
- Power losses on the driver should be avoided completely and thus the highest possible energy efficiency should be achieved.

All LEDVANCE LED TUBE T8 EM, UNIVERSAL, T5 AC, T9 EM and DULUX LED are suitable for operation on 230V AC mains.

It is required to check if the existing luminaire is suitable for conversion from a technical and photometrical point of view. Conversion is only allowed to be conducted by a qualified electrician. After conversion a risk assessment has to be conducted. If no significant changes have been made to the performance, application or construction of the luminaire or if risks are not being increased by any significant change, its existing CE mark will remain valid and no new declaration of conformity is needed.

This [checklist](#) can be used as assistance for the risk assessment:



Luminaire to be rewired with built in reflector (above), with removed reflector (below)



Tools needed: wire cutter, wire stripper, different screwdrivers

New wires must comply with latest version of EN 50525 and EN 60598-1, have a minimum cross section of 0,4 mm² and the isolation have a nominal thickness of 0,5 mm.

Material included in conversion kit



Content conversion kit:

- Pre-wired micro fuse (T2A 250V)
- 4 cable ties
- 4 WAGO connectors
→ Conversion of double-flame luminaires requires two additional 3-conductor WAGO connectors

1. General Work Steps ECG Luminaire

Direct wiring circuit diagram of luminaires on AC mains

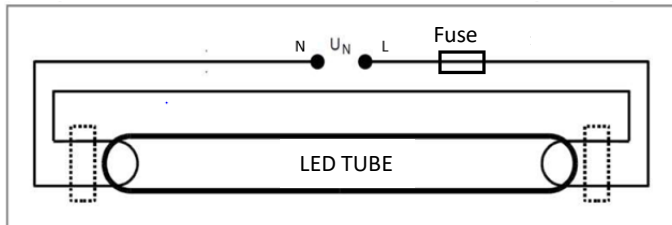

Single-flame luminaire

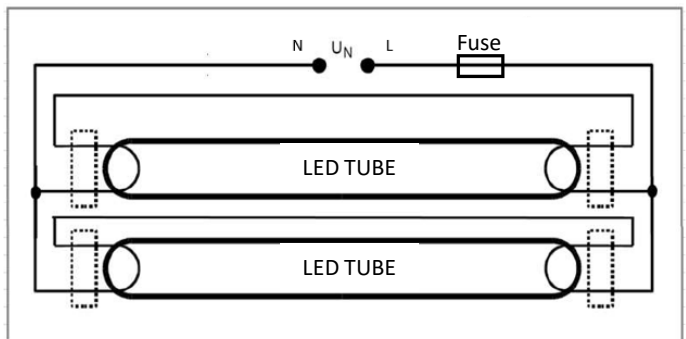

Double-flame luminaire

Remove wiring from ECG step by step and re-connect as prescribed below



Step 1: Connect mains line "L" to fuse with one wire using a WAGO connector

Step 2: Connect second fuse line to right lamp holder(s). Pay attention to correct connection of all ECG clamps within the following steps.

Step 3: Connect right lamp holder(s) to left lamp holder(s).

Step 4: Connect second line from left lamp holder(s) to neutral wire "N". Use WAGO connector if needed.

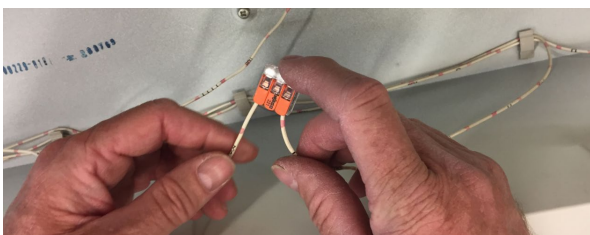

Step 5: Remove ECG.

Step 6: Fix all wires in existing cable mounts and install cable ties in addition.

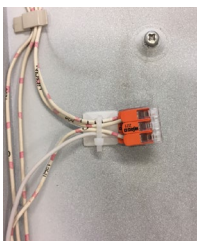

1. General Work Steps ECG Luminaire

Schritt 7: Risk assessment according to evaluate whether significant changed have been made to the performance, application or construction of the luminaire.

This [checklist](#) can be used as assistance for the risk assessment:

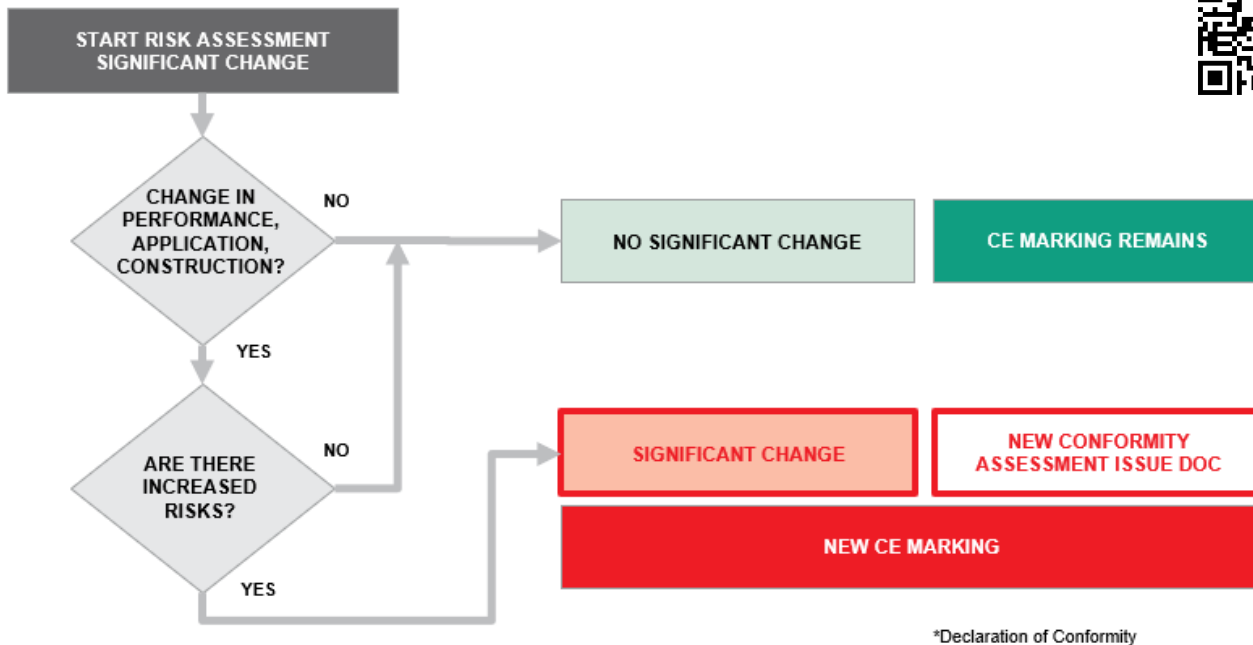

Step 8: Fix the provided warning sticker clearly visible inside of the luminaire. The converted luminaire should not be used anymore with fluorescent lamps.

WARNING: THIS LUMINAIRE HAS BEEN MODIFIED TO OPERATE ONLY AC 220-240V LED TUBE. NOT FOR USE WITH ANY FLUORESCENT LAMP

Step 9: Conduct final visual inspection of all components and check if all wires have been fixed tightly inside of the WAGO connectors. Cables should not be pinched during the mounting of the luminaire. Defect parts must be repaired or replaced.



If needed, re-connect earth conductor (PE)



Single-flame luminaire



Double-flame luminaire

3. General Work Steps CCG Luminaire

Circuit diagram of luminaires with traditional CCG, fluorescent lamp and starter

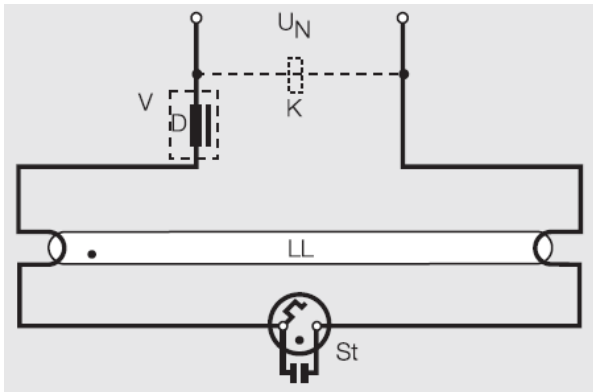

Single-flame luminaire

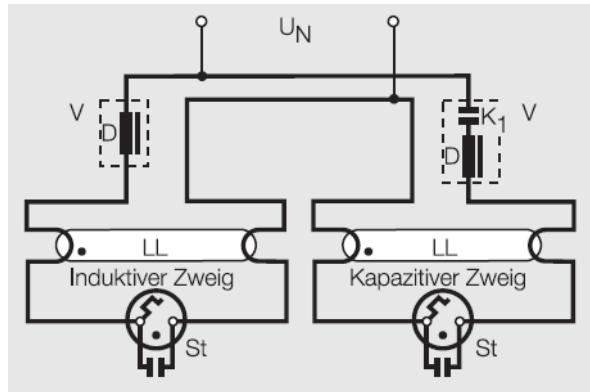

Double-flame luminaire

Remove wiring from CCG step by step and connect as described, if applicable remove compensation capacitor as well

Circuit diagram of a rewired, single-flame luminaire with LED tube on AC mains

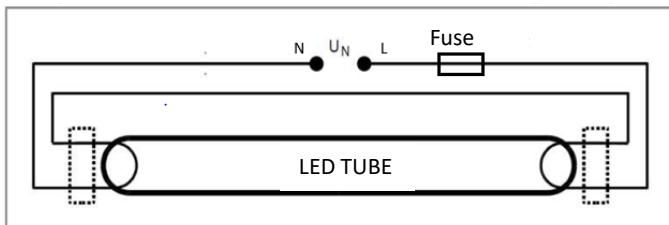

Single-flame luminaire

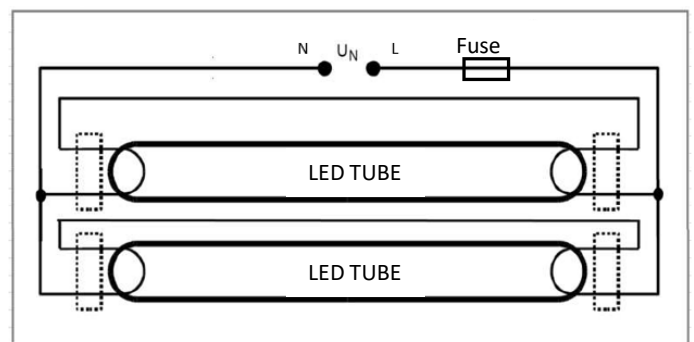

Double-flame luminaire

Step 1: Connect mains line "L" to fuse with one wire using a WAGO connector.

Step 2: Connect second line of fuse with the left lamp holder.

Step 3: Remove starter holder to establish a connection between the right and left lamp holder

Step 4: Connect cables leading to starter holder using a WAGO connector.

Step 5: Remove CCG.

Step 6: Fix cables using existing cable brackets and mount additional cable ties and adhesive sockets.

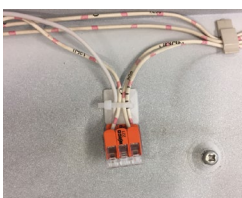

4. Connection diagrams DULUX LED

The same work steps for conversion can be followed for LEDVANCE DULUX LED lamps. For AC mains connection please note the following layouts:

DULUX LED D & T

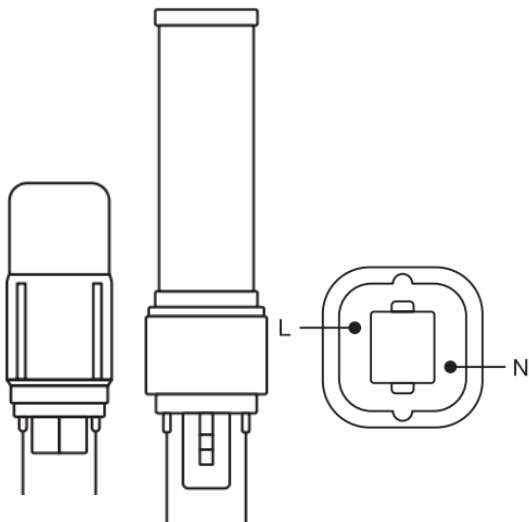

DULUX LED D/E & T/E

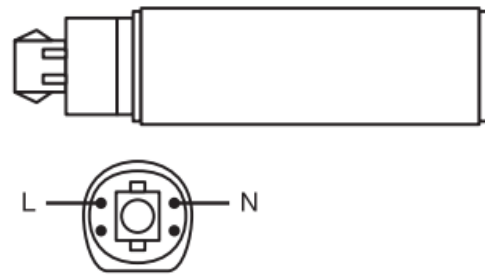

Single-flame luminaire

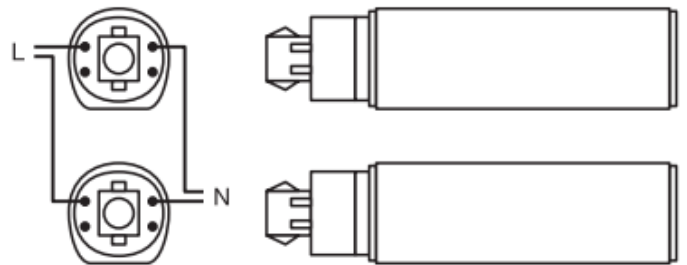

Double-flame luminaire

DULUX LED L



Single-flame luminaire

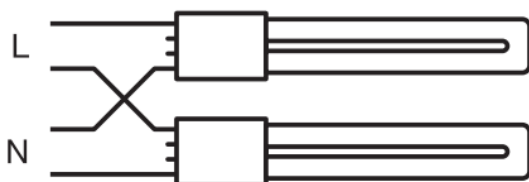

Double-flame luminaire

DULUX LED F

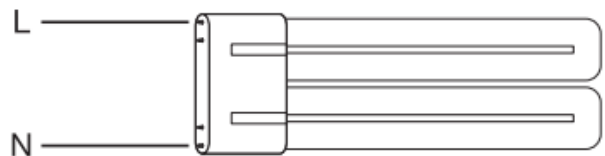

Single-flame luminaire

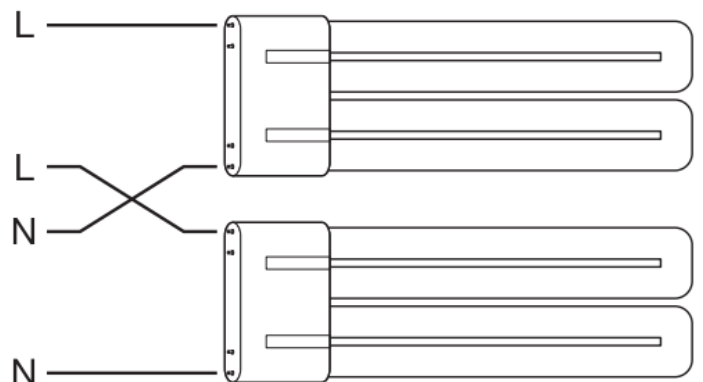

Double-flame luminaire

4. Connection diagrams DULUX LED

DULUX LED S

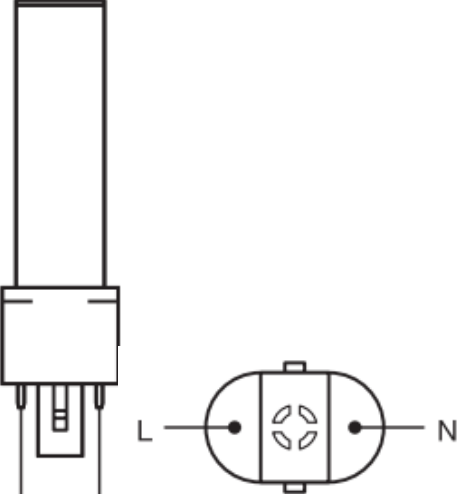

DULUX LED SQUARE

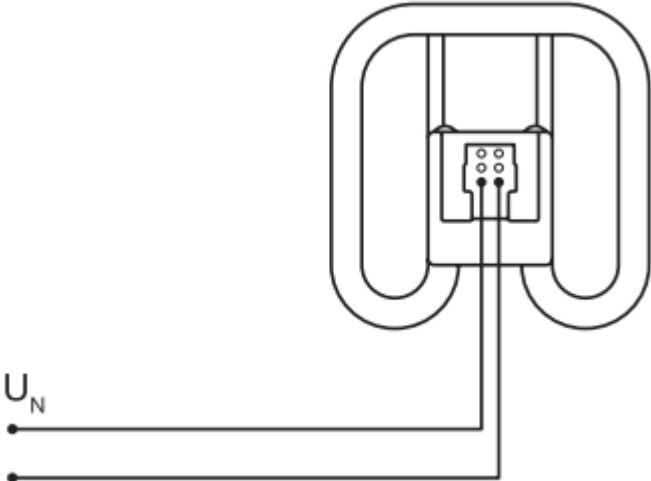

ABOUT LEDVANCE

With business activities in over 140 countries, LEDVANCE is one of the world's leading general lighting companies. Emerging from OSRAM's general lighting division, LEDVANCE's portfolio includes LED lamps and luminaires, intelligent lighting products, traditional lamps and renewable energy solutions.

#POWERTHROUGHLIGHT



LEDVANCE

LEDVANCE GmbH
Parkring 1 – 5
85748 Garching
Germany