

Placeholder product name

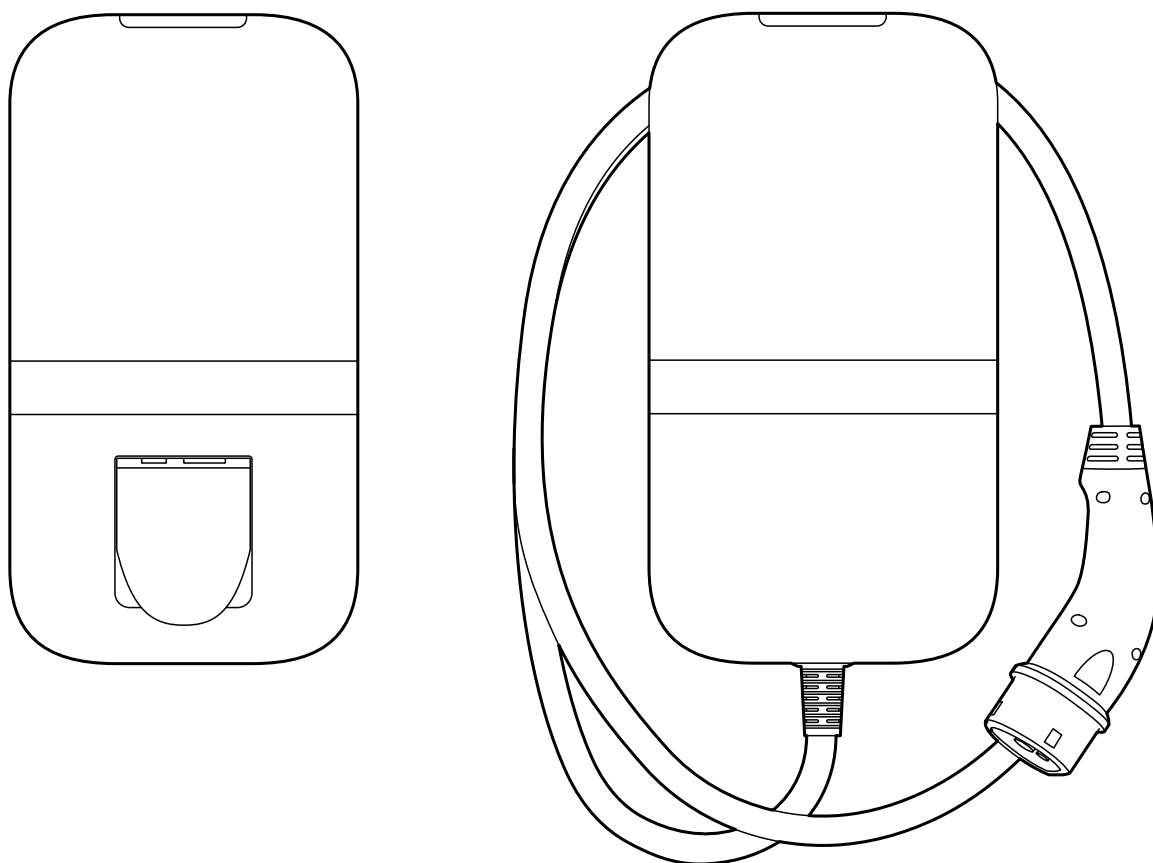



Table of contents

1	User manual.....	3
1.1	Introduction.....	3
1.2	Safety and usage information	3
1.3	Product information	4
1.4	Charging your vehicle.....	6
1.5	Product configuration	7
2	Installation manual.....	8
2.1	Introduction.....	8
2.2	Product information	8
2.3	Safety instructions	11
2.4	Installation	12
2.5	Commissioning.....	27
2.6	Decommissioning.....	28
2.7	Transportation, storage.....	29
2.8	Disposal	29
	Appendix A: Model identification string	30
	Appendix B: Troubleshooting	31
	Appendix C: EU - Declaration of conformity.....	32
	Appendix D: Glossary.....	32

1 User manual

1.1 Introduction

This part of the manual explains the use of the charger for the user. It is important that the user reads the safety and usage information before using the charger.

Used symbol	Definition	Explanation
	WARNING	Potential hazardous situation which, if not avoided, could result in death or serious injury.
	Attention	Risk of undesired behavior of the charger

1.2 Safety and usage information

The charger is intended exclusively for charging electric vehicles. Read and follow the safety precautions before using the charger. A qualified installer must ensure that the charger is installed in accordance with the relevant country-specific standards and local regulations. Retain this manual for future reference.



WARNING: The electrical supply must be switched off before the front assembly is opened or any installation, maintenance or repair work is undertaken.



WARNING: Using this product is prohibited near flammable substances.



WARNING: Do not use the charger or charging cable when it is damaged.

Attention: Only use the charger at temperatures between -30 and +50 degrees Celsius.

Attention: Place the protective cap on the vehicle connector when not using the charger.

Attention: Do not apply excessive force on the charging cable.

Attention: Do not leave the vehicle connector of the charging cable on the ground.

Attention: Only clean the charger with a dry cloth. Do not use aggressive cleaning brands Do not use a pressure washer.

Attention: This product should be used with a minimum distance of 25 cm to your body.

Attention: Do not use adapter plugs with the charger.

Attention: Do not use extension cords with the charger.

Attention: Do not remove or adjust any markings, warning symbols or the label of the charger.

1.3 Product information

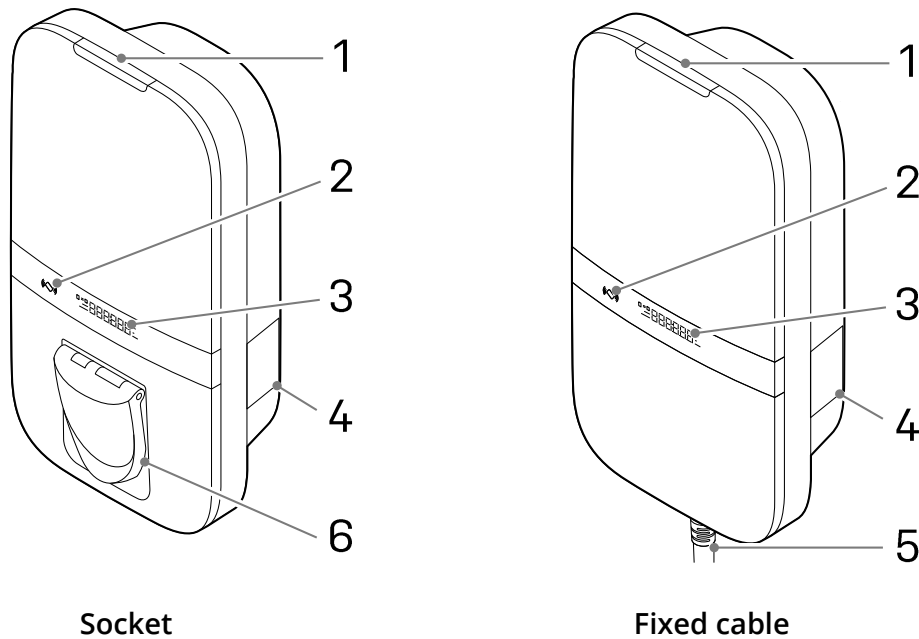

Parts overview

The table below explains the numbered items in the figure.

1. LED status indicator	4. Label
2. RFID scanner	5. Type 2 charging cable*
3. Display (optional)	6. Type 2 socket*

* either the socket or the charging cable is present

On the label (**4**), the model type is printed. This provides information about the applicable features of the charger, which are further explained for all charger variants in **Appendix A**.

Status indication

The table below shows the options for the top LED status indicator (**1**).

LED feedback		Charger status
Yellow	●	Start-up / not commissioned / unavailable
Green	●	Ready to use, no EV connected / EV connected, but not authorized
Blue	●	Authorized
Pulsating blue	⦿	Charging
Blinking red	●	Error detected. See Appendix B for troubleshooting

Display

Optionally the charger is equipped with a display to present energy metering information from the current charging session with a resolution of 0.01 kWh. The figure below explains the information.

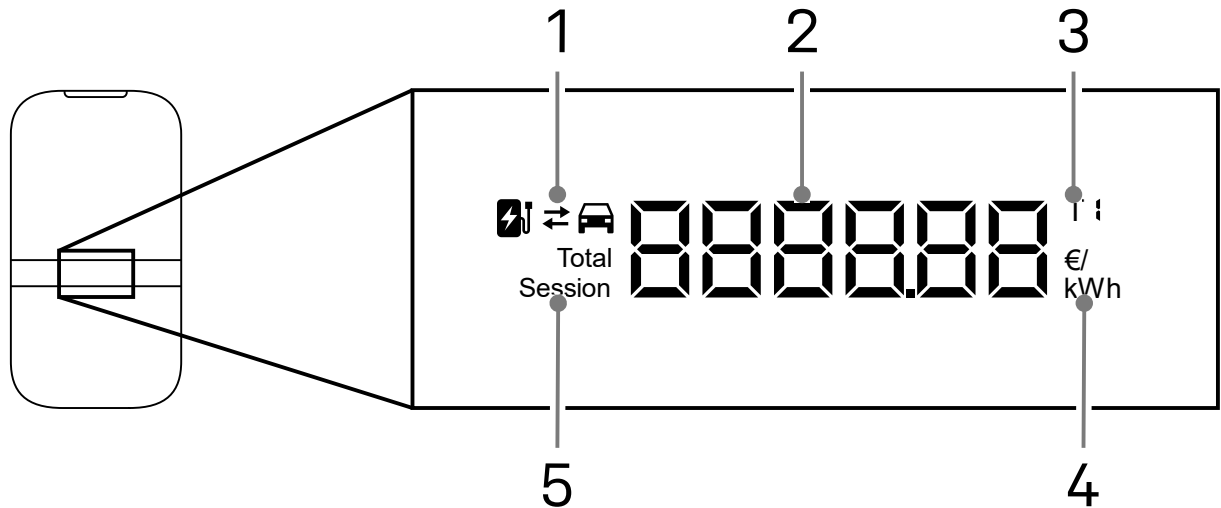

1. Charging or discharging

2. Energy charged current session / total energy charged over lifetime / costs of the charging session / energy tariff

3. Indication for energy tariff displayed

4. Unit of displayed number, kWh, €, or €/kWh

5. Indication whether displayed energy corresponds to current session or total energy over lifetime

1.4 Charging your vehicle

Attention: Unwind the charging cable completely when charging your vehicle.

Start charging your vehicle

The charger is ready for charging when the LED status indicator is green. Plug the charging cable into the socket (if applicable) and into your electric vehicle.

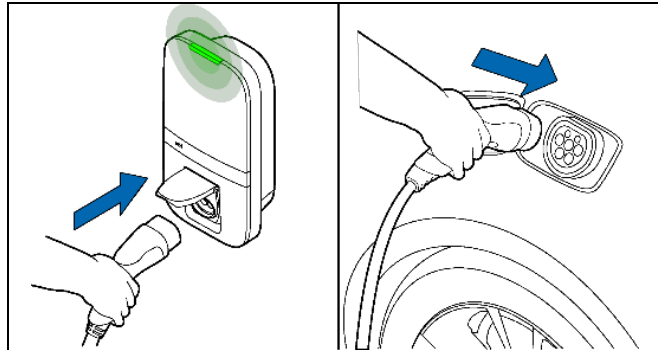

Hold your RFID card/tag in front of the reader to start charging. The status LED flashes green for a second and a beep is emitted when the RFID card/tag has been read. If the charger has a socket, the cable will now be locked to the charger.

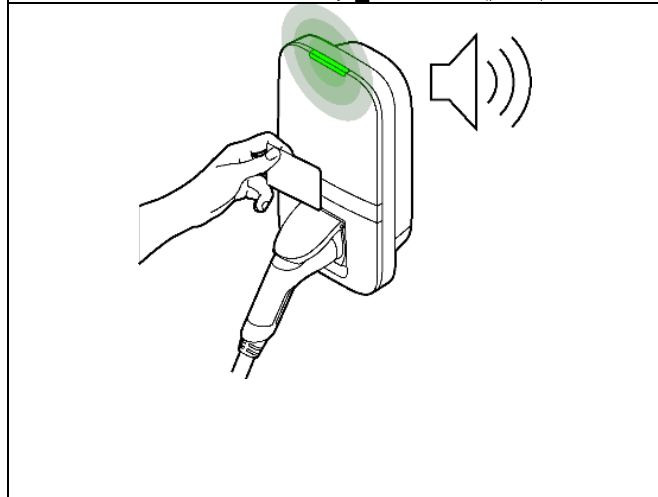

For automatic starting of charging the RFID authorization can be disabled (see section 1.5)

The vehicle is being charged; the LED status indicator is pulsating blue. This might take a few seconds.

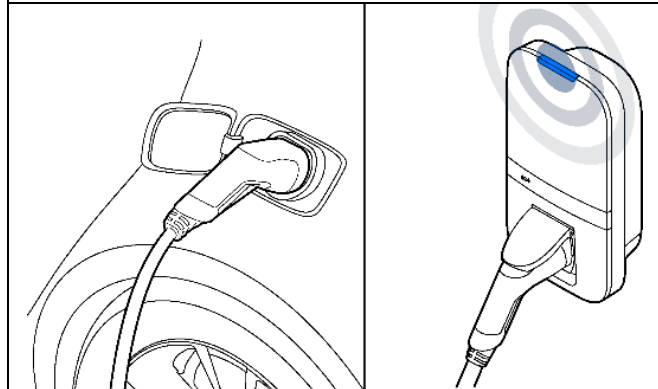

Stop charging your vehicle

Attention: Do not pull the charging cable when unplugging; pull the connector of the charging cable instead.

Hold your RFID card in front of the reader to stop charging. The LED status flashes green for a second and the charger emits a beep when the RFID card/tag has been read. The session is now finished.

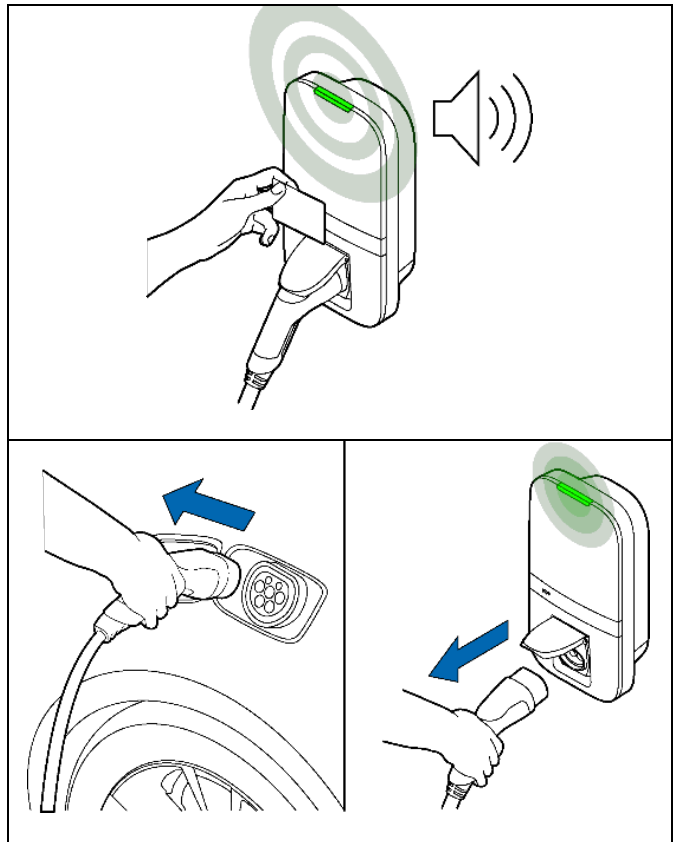

Unplug the charging cable from your electric vehicle. If the charger has a socket the charging cable can be unplugged from the charger.

1.5 Product configuration

Connect to the WLAN access point of your charger using e.g. a phone or laptop. The network hostname SSID and password are printed on the label on the back of the supplied manual or quick start guide. The QR code on this label can also be scanned with a mobile phone to connect to the charger's access point.

Another way to reach the web interface is to plug in an ethernet cable into both your computer and the charger.

Browse to the hostname in your browser and log in to the web interface using the password provided with the charger, located at the back of the supplied manual or quick start guide. In the dashboard, multiple settings can be adjusted or observed. The web interface will explain the definition of these settings.

2 Installation manual

2.1 Introduction

This part of the manual describes how to install the charger. It is important that you read the safety instructions before you start.

Intended audience

The installation manual is intended exclusively for qualified installers who can assess the work and identify potential danger.

2.2 Product information

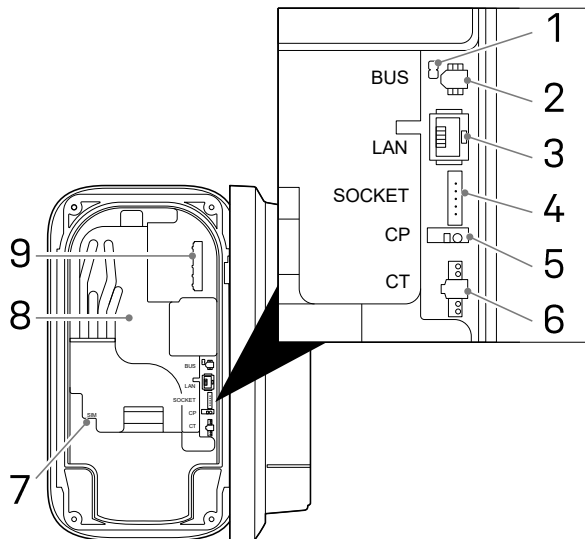

Interface overview

The table below lists all possible connectors on the charger. Consult the identification string in **Appendix A** to see what is present in the charger.

1. BUS termination jumper*
2. BUS connector*
3. Ethernet connector*
4. Socket connector*
5. Control pilot connector*
6. CT coils connector
7. SIM card holder*
8. Energy meter accuracy LED*
9. Mains connector

* *Optional*

Specifications

The table below lists the detailed specifications of this product. Note that not all specifications may apply to the charger. The model identification string in **Appendix A** determines the applicable specifications.

General	
Charger type	IEC 61851 AC mode 3
EV plug / socket connection	IEC 62196 Type 2
Rated output current (depending on variant)	16 A or 32 A
Rated voltage	230 V AC (1-phase) or 400 V AC (3-phase)
Nominal power	Up to 22 kW
Rated frequency	50 Hz

Dimensions (H x W x D, ex. cable)	387 x 207 x 128 mm	
Weight (excl. cable)	Approx. 2.9 kg	
Charge cable length	4.5 m, 5 m or 7.5 m	
User interface	Multicolor LED, buzzer, display	
Ventilation (IEC 61851 state D)	Not supported	
Intended use	Residential, commercial, and industrial applications	
Safety		
Current leakage protection	6 mA DC earth leakage protection	
Safety class	Class I	
Overvoltage category	Category III	
Disconnection prevention socket	Locking mechanism	
Authorization		
Authorization methods	RFID (Mifare classic & Mifare DESfire), Plug and Charge (ISO15118)*	
Energy meter		
Energy meter class	Class B	
Certification (depending on variant)	MID Mess & Eichrecht (DE)	
Environmental		
Operating temperature	-30 °C to +50 °C	
Ambient storage temperature	-40 °C to +85 °C	
Relative humidity range	5% to 95%	
Maximum operating altitude	3000 m	
IP rating	IP54	
IK rating	IK10	
Connectivity		
WLAN	2.4 GHz with WPA2	
Fixed network	Ethernet 100 Mbit	
Cellular	LTE Cat-M1, NB-IoT, GPRS	
SIM size	Nano-SIM (4FF)	
Frequency bands		
Technology	Band	Maximum radiated output Power (dBm)
(E)GPRS	900	36
(E)GPRS	1800	33
LTE	1	23.7
LTE	3	23.7

LTE	8	23.7
LTE	20	23.7
LTE	28	23.7
802.11b/g/n	2400	19.99
Supported protocols		
Vehicle communication	IEC 61851-1 ISO 15118-2* ISO 15118-20*	
Back-end communication	OCPP 1.6J (including security whitepaper) OCPP 2.0.1*	
Firmware update	Locally via web interface Over-the-air via OCPP	
Blackout protection / load balancing		
Static	Configurable current limit	
Dynamic	Hardwired via CT coils P1 Dongle	
Group load balancing	RS-485 (leader or follower)	
Installation		
Installation location	Indoor and outdoor usage	
Mains connection	Permanent mains connection only	
Installation type	Stationary equipment. Wall or pole mounted	
Recommended installation cable use**		
3-phase 22kW, cable length: <25M	5x4mm ²	
3 phase 22kW, cable length: >25M	5x6mm ²	
3-Phase 11kW, cable length <25M	5x2.5mm ²	
3-Phase 11kW, cable length >25M	5x4mm ²	
1-Phase 7kW, cable length <25M	3x4mm ²	
1-Phase 7kW, cable length >25M	3x6mm ²	

* Hardware prepared

** Check local installation requirements

2.3 Safety instructions

Read and follow the safety instructions below. Incorrect installation, repairs or modification can result in danger and may void the warranty.

Used symbol	Definition	Explanation
	WARNING	Risk of failure of the charger
	Attention	Risk of undesired behavior of the charger



WARNING: The installation must be carried out by a qualified installer who has read this manual. Failure to follow the instructions in this manual may result in serious injury or death.



WARNING: Switch off the mains input power before installing the charger.



WARNING: Keep the power off until the charger is installed, and you have reached step 11 in the instructions list.



WARNING: Do not install a faulty or damaged charger.



WARNING: Do not install the charger in wet weather conditions or when the humidity exceeds 95%.



An upstream circuit breaker (MCB) and residual current device (RCD) must be installed. The MCB (characteristic B or C) shall have a current rating in accordance with the local mains supply and required charge current (max 32A). The RCD shall be type A (30 mA) or type B (30mA) depending on local regulations.

Attention: Check local installations standards for additional requirements.

2.4 Installation

Contents of the box

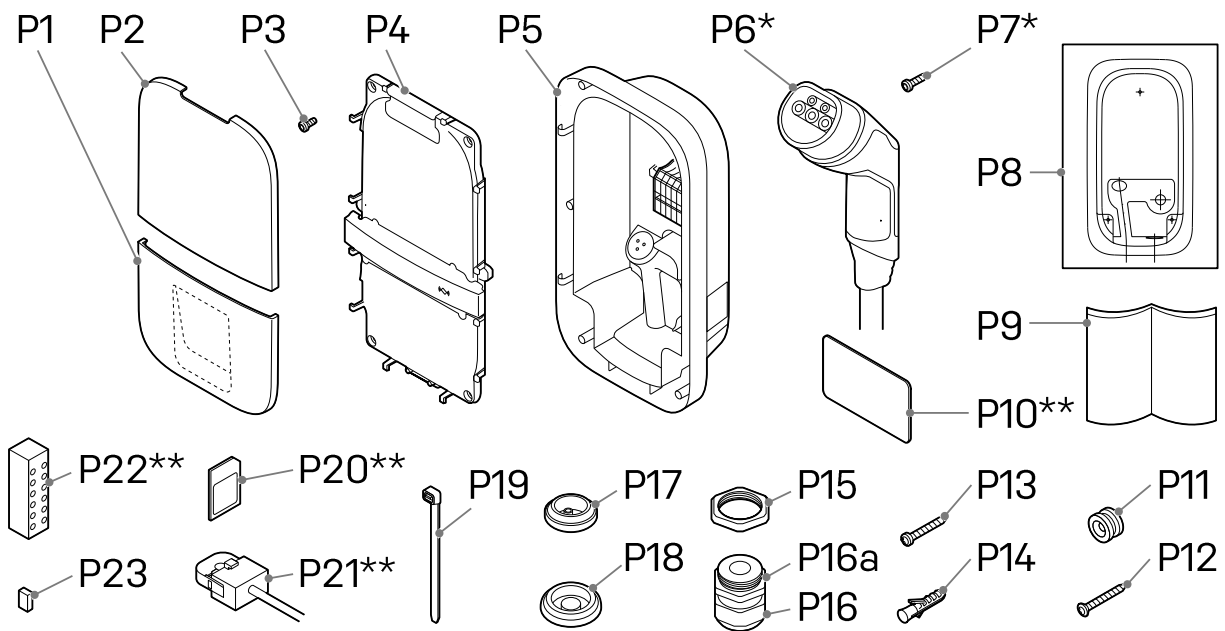

Number	Definition	Size	Quantity
P1	Bottom cover	-	1
P2	Top cover	-	1
P3	Screw for front assembly/charging cable*	M4x10 mm	6 (+5*)
P4	Front assembly	-	1
P5	Base assembly	-	1
P6	Charging cable*	4.5, 5 or 7.5 m	1
P7	Screw for charging cable*	3x10mm	2
P8	Charger template	-	1
P9	Manual/quick start guide	-	1
P10	RFID card**	-	1
P11	Mounting ring	-	1
P12	Rear wall countersunk screw	5x60 mm	1
P13	Rear wall pan head screw	5x50 mm	2
P14	Wall plugs	8 mm	3
P15	Cable gland nut	M32	1
P16	Cable gland	M32	1
P16a	Cable gland reduction insert	-	1
P17	Grommet for peripherals	M25	1
P18	Grommet for mains cable	M32	2
P19	Cable tie for peripherals/charging cable	-	4(+3*)
P20	SIM card**	-	1
P21	CT coils**	-	1 (1-phase) 3 (3-phase)

P22	Distribution block for CT coils**	-	1
P23	BUS termination jumper	-	1

* Cable variants

** Optional

Required tools

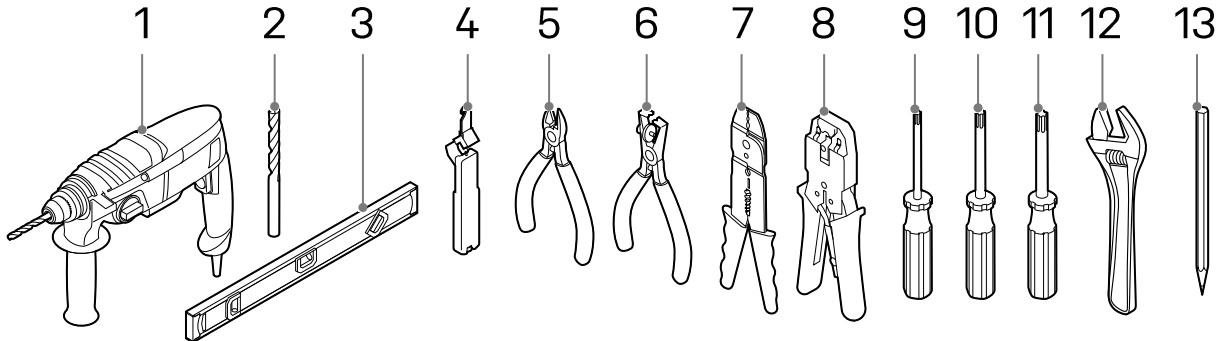

Number	Definition	Size
1	Power drill	-
2	Drill bit	8 mm
3	Spirit level	-
4	Cable stripper	
5	Cable cutter	-
6	Wire stripper	-
7	Wire stripper	2 mm
8	Ethernet crimping tool	
9	Torx screwdriver	T10
10	Torx screwdriver	T20
11	Torx screwdriver	T30
12	Adjustable wrench	-
13	Pencil	-

Step 1: Choose charger location

- Install the charger in a location that allows the charge cable to reach the vehicle charge port without putting strain on the cable.
- Avoid installation in direct sunlight for optimal performance of the charger.
- The recommended free space around the charger is ≥ 300 mm.
- The recommended height of the mounting ring is 1400 mm.
- When the charger is equipped with a fixed cable, the lowest point of the vehicle connector when stored shall be located at a height between 0,5m and 1,5m above ground level.
- Check local accessibility regulations.

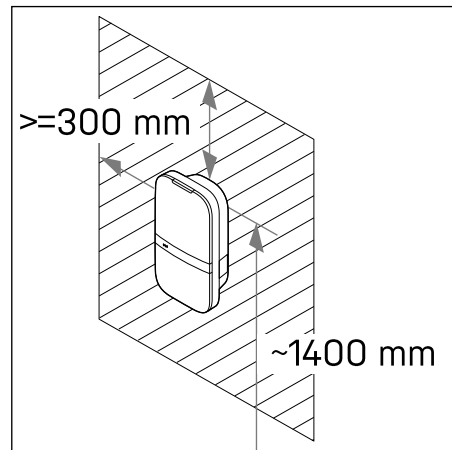

Attention: The wall must have a flat structure and must be able to hold a sufficient load. This installation procedure is meant for a concrete or brick wall. If another mounting surface is used, ensure that appropriate screws and/or plugs are used.

Step 2: Select the hole where the mains cable should enter the charger

The two holes indicated with numbers **H1** and **H2** can be used for inserting the mains cable. Select the hole where the mains cable should enter the charger.

When the back hole is selected (indicated with **H1** in the figure) follow **steps 3-4**.
When the lower hole is selected (indicated with **H2** in the figure) follow **steps 5-6** on page 18.

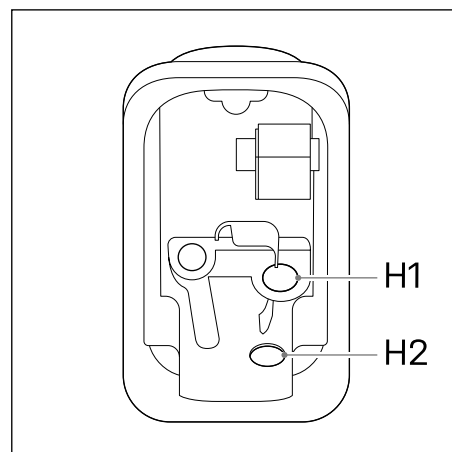

Step 3: Back hole – preparation

- Use the cardboard template (**P8**) and a spirit level to mark the holes for the mounting screws and mains cable.

Attention: Make sure that the mains cable entry matches, and is centered, to the back hole in the template.

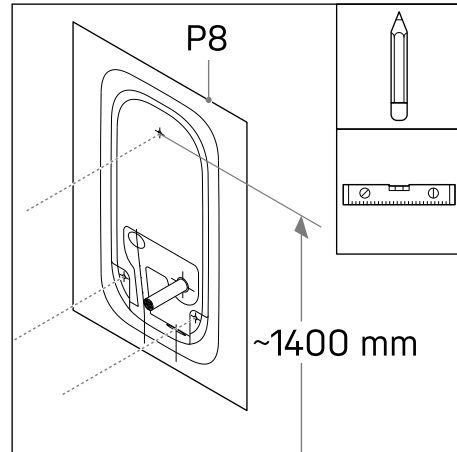

- Drill three 8 mm holes at the marked locations.
- Insert plugs (**P14**) into the drilled holes.
- Tighten the mounting ring (**P11**) with countersunk screw (**P12**) to the upper plug in the wall.

Attention: The mounting ring is assymmetric. The flat end must be placed against the wall

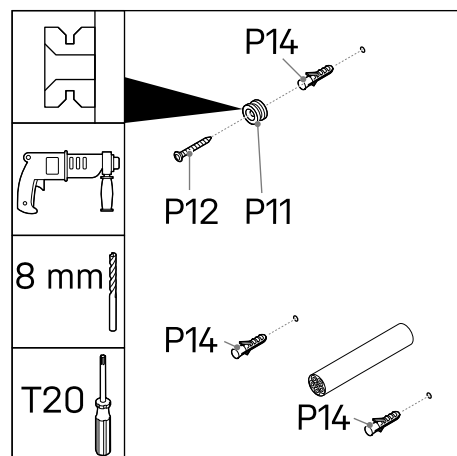

Step 4: Mounting the base assembly

- Strip the mains cable at 30 mm from the wall.

Attention: Keep the cables at least 200 mm long so you can cut them to the desired length later.

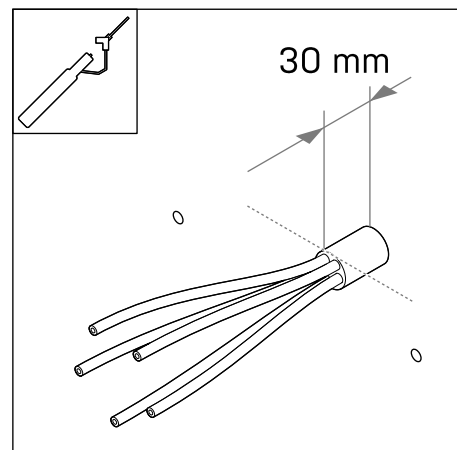

- The front assembly (**P4**) and the base assembly (**P5**) can be detached from each other.
- You can detach the two parts by disconnecting the connector (**1**) from the front assembly.

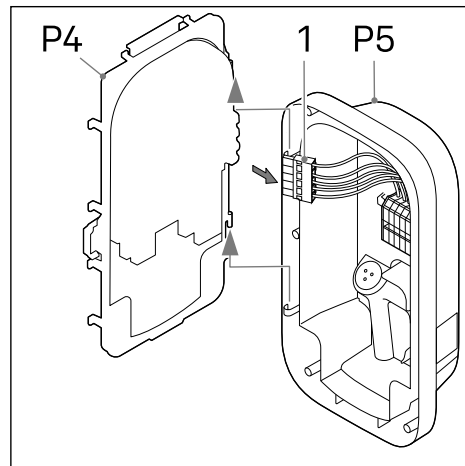

- Insert the grommet (**P18**) in the bottom-right hole (**H2**).
- Insert the grommet (**P17**) in the bottom-left hole (**H3**).

Attention: Ensure that grommets are inserted correctly, to guarantee resistance to ingress of water and dust.

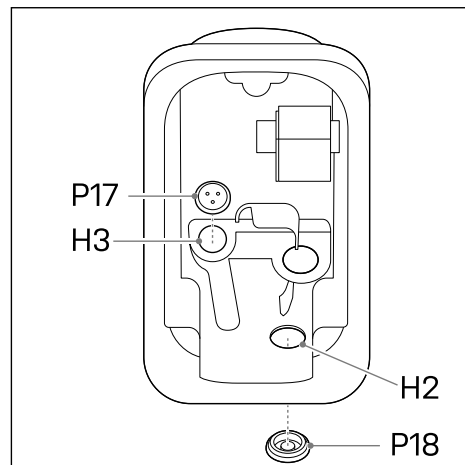

- Create a hole in the center of the grommet (**P18**) and insert the grommet in the back hole.
- Push the mains cable (**1**) through the grommet located in the back.
- Attach the base assembly to the mounting ring (**P11**) and press down firmly.
- Put the two pan head screws (**P13**) loosely through the bottom mounting holes, level the base assembly and tightening the screws.

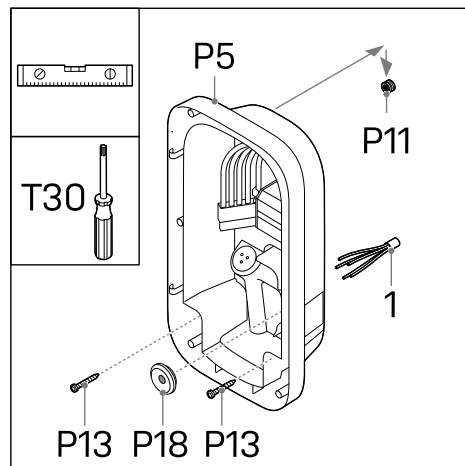

- Cut off the power cables at the right length to push them in the DIN rail terminal block (1). The route of the cables should be as short as possible.
- Strip the power cables at 10 mm.

Go to step 7 on page 20.

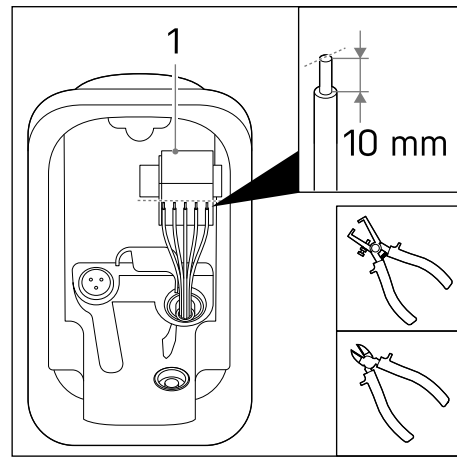

Step 5: Lower hole – preparation

- Use the cardboard template (P8) and a spirit level to mark the holes for the mounting screws and mains cable.

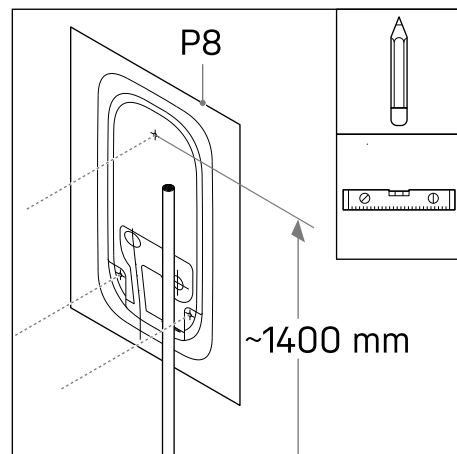

- Mark and strip the mains cable at 10mm above the mains wire entrance as indicated on the template.

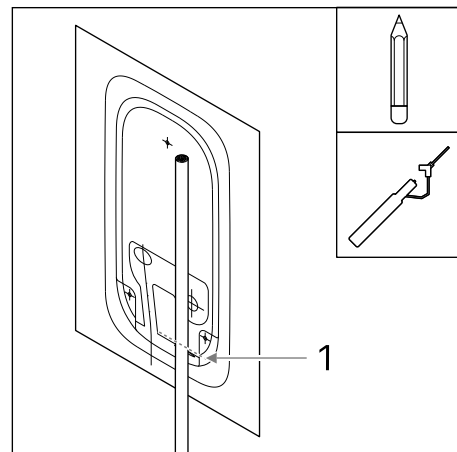

Attention: Make sure that the mains cable matches, and is centered, to the right dotted line on the template.

- Drill three 8 mm holes at the marked locations.
- Insert plugs (P14) into the drilled holes.
- Tighten the mounting ring (P11) with countersunk screw (P12) to the upper plug in the wall.

Attention: The mounting ring is asymmetric. The flat end must be placed against the wall

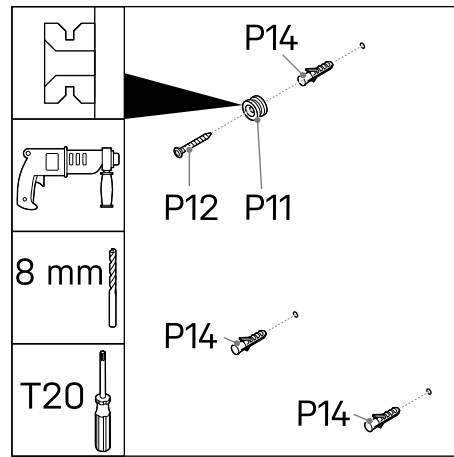

Step 6: Lower hole – Mounting the base assembly

- The front assembly (P4) and the base assembly (P5) can be detached from each other.
- You can detach the two parts by disconnecting the connector (1) from the front assembly.

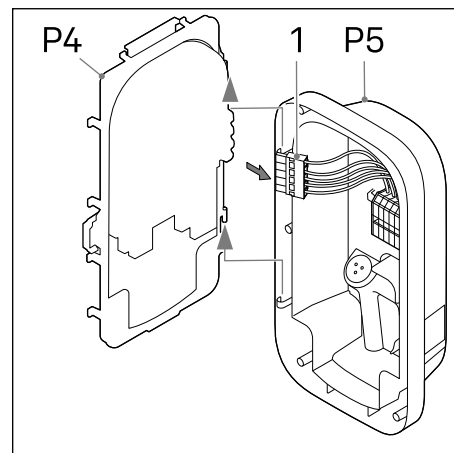

- Insert the grommet (P18) in the back hole (H1).
- Insert the grommet (P17) in the bottom-left hole (H3).
- Place the cable gland nut (P15) above the bottom-right hole (H2) and fasten it with the cable gland (P16) at 10 Nm using the adjustable wrench.
- Only for a mains cable with a diameter of 9 – 14mm place the reduction insert (P16a) into the cable gland.

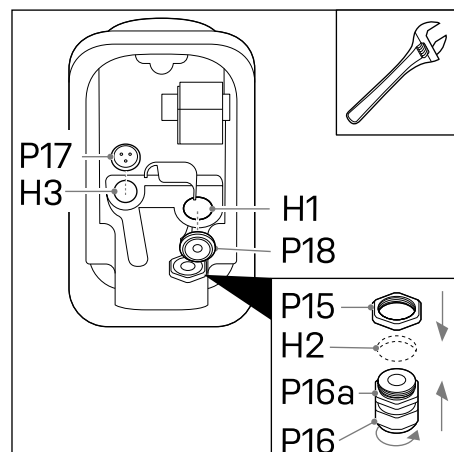

Attention: Ensure that grommets and the cable gland are inserted correctly, to guarantee resistance to ingress of water and dust.

- Insert the mains cable (**1**) in the cable gland sealing nut and base assembly. Do not yet secure the sealing nut.
- Attach the base assembly to the mounting ring (**P11**) and press down firmly.
- Put the two pan head screws (**P12**) loosely through the bottom mounting holes, level the base assembly and tightening the screws.

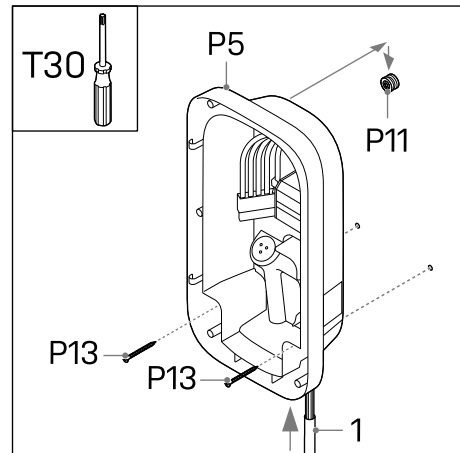

- Fasten the cable gland sealing nut with 10 Nm using the adjustable wrench.
- Cut off the power cables at the right length to reach the DIN rail terminal block (**1**). The route of the cables should be as short as possible.
- Strip the power cables at 10 mm.

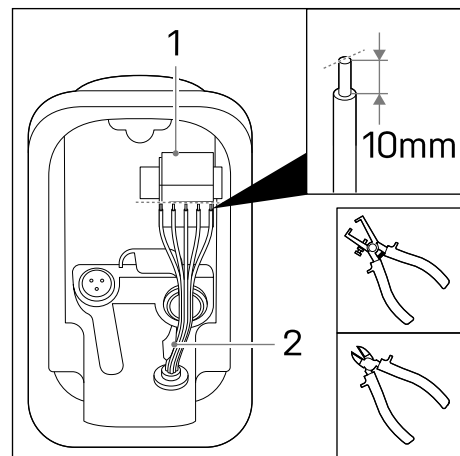

Attention: Ensure that the power cables are located right from the bracket (**2**).

Step 7: Mains connection

- When installing multiple chargers on one grid connection, check 7a
- When installing the charger in a IT grid (three phase without neutral), check 7b
- Connect the power cables for L1, L2*, L3*, PE and N to the correct DIN rail terminal block push-in connector in the base assembly.
* only present in three-phase variant of the charger

The figure indicates which push-in connector corresponds to the phase, neutral or ground.

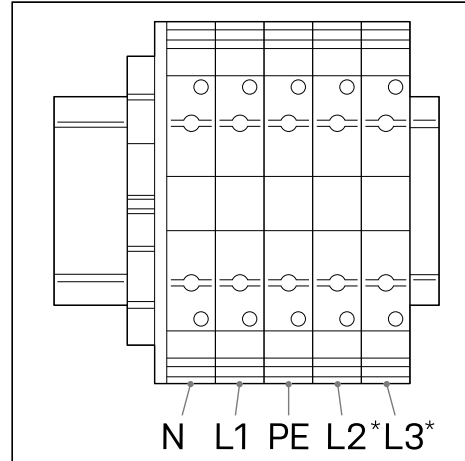

Attention: Do not connect the phase cables L1, L2 or L3 in the PE or N connectors.

Step 7a: Phase rotation

It is essential to rotate the phases when connecting multiple chargers on one grid connection, to evenly distribute the load and prevent phase unbalance. The figure below shows the different names of the phase rotations. Phase 1 is indicated with an 'R' (rotary), phase 2 with an 'S' (secondary) and phase 3 with a 'T' (tertiary).

Attention: Write down the name of the phase rotation you apply, as you need it later during commissioning of the chargers.

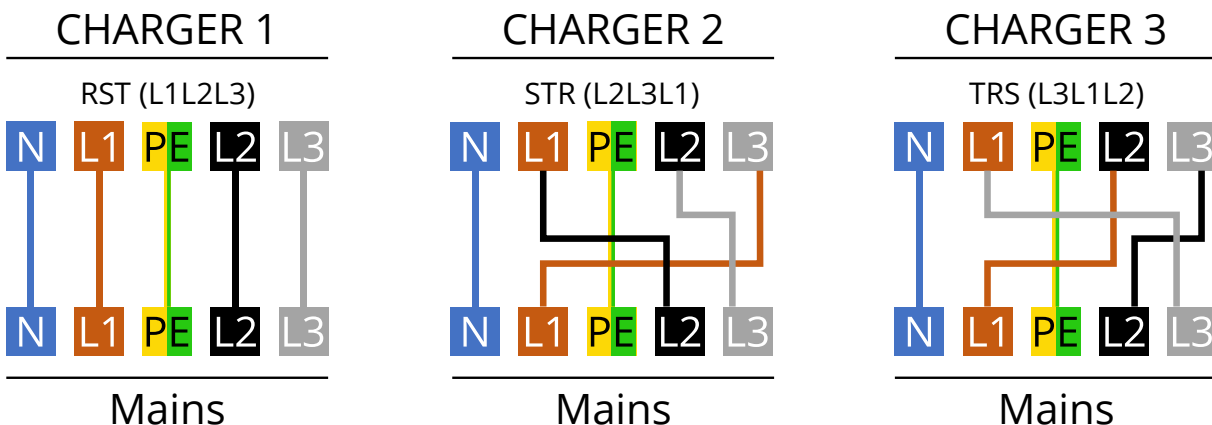

Recommended order for the connection:

Charger 1	Charger 2	Charger 3	Charger 4	Charger 5	Charger 6	Etc.
RST (=L1L2L3)	STR (=L2L3L1)	TRS (=L3L1L2)	RST (=L1L2L3)	STR (=L2L3L1)	TRS (=L3L1L2)	...

Step 7b: IT grid 3x230 V

- When an IT-grid (three phase 230 V without neutral) applies, connect the cables as indicated. L3 on charger side remains free.

Attention: Only use this diagram after checking the current of 230 V between phases. Connecting any other grid system according to this diagram will lead to permanent damage to the charger.

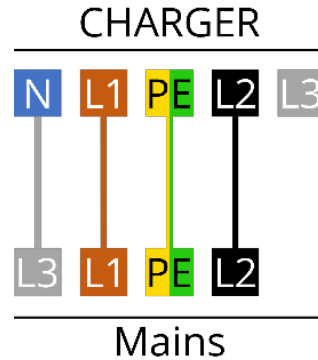

Step 8: Install charging cable*

* *Optional*

- Attach the strain relief of the charging cable (**P6**) to the front assembly using the two screws (**P7**) at 1.1Nm.
- Route the cables underneath the notch (**1**) and mount the power cables with the screws (**P3**) to the correct phases (L1, L2, L3), neutral (N) and ground (PE) at 2 Nm, as indicated in the figure.
- Insert the white CP cable in the CP push in connector on the board (**2**).
- Secure the power cables with cable ties (**P19**).

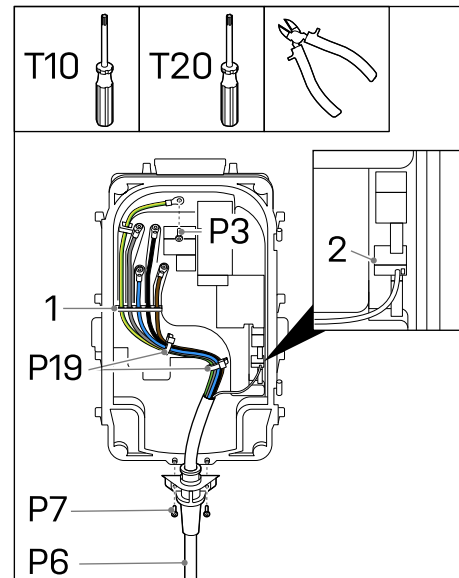

Attention: Connect the phases, neutral and protective earth with the correct connector in the cover. The correct order is indicated on the cover: **PE – L3 – N – L2 – L1**

Step 9: Install peripherals

- Attach the front assembly (**P4**) to the base assembly (**P5**).

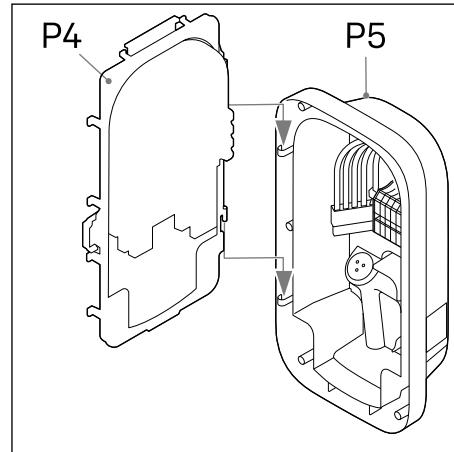

Attention: It is recommended to use a shielded Cat-5 (or higher) cable for connecting the peripherals to the charger.

Ethernet*

- Make a hole in the grommet for peripherals (**P17**).
- Push the Cat cable through the grommet.
- Strip the cable and attach an RJ-45 ethernet connector (**2**).
- Plug the ethernet cable in its connector (**1**).
- Secure the cable using cable ties (**P19**).

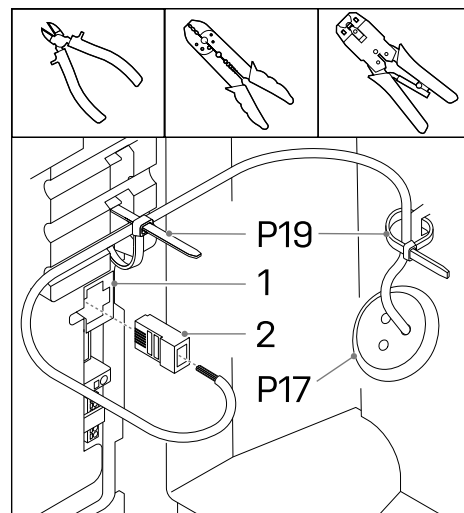

Install load balancing kit with CT coils*

The load balancing kit is mostly used in home applications, to prevent potential blackouts. When the power usage of the house is high, and the vehicle is charging at the same time, the load balancing feature will lower the charging current in these situations.

Attention: Connecting the signal wires of the CT coils incorrectly may cause the charger to exceed the configured charging current.

Attention: It is recommended to use a shielded Cat-5 (or higher) cable. The maximum length of this cable is 150 meters.

- Mount the CT coil(s) (**P21**) over the phase cable(s) (**1**) in the fuse box in the house right after the main switch.
- When opening the CT coils, you can see an arrow. This arrow defines the direction of the current in the fuse box. Place the coil over the phases in the correct direction for correct measurements

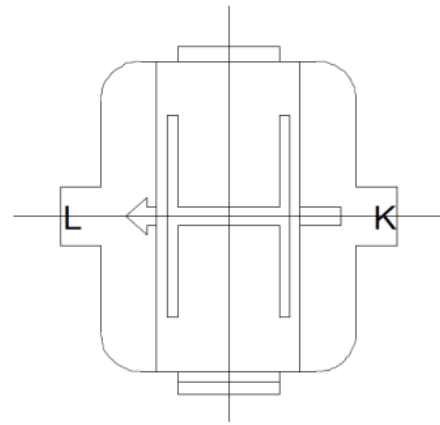

- Attach the wires of the CT coil(s) to the distribution block (**P22**).
- Connect the wires of a signal cable (**2**) to the corresponding pins in the distribution block. Label which cable belongs to which polarity of the CT coil.
- Secure the distribution block to a suitable place in the fuse box.

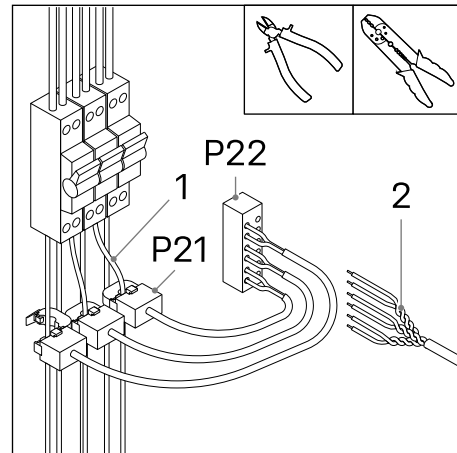

- Cut an (additional) hole in the grommet placed for peripherals (**P17**) and push the signal cable through the hole in the grommet.
- Strip the signal cable and its wires (**2**).
- Connect the signal wires to the push-in connector for dynamic load balancing (**1**), indicated with CT. The figure displays the connector definition per pin.
- Secure the cable using a cable tie (**P19**)

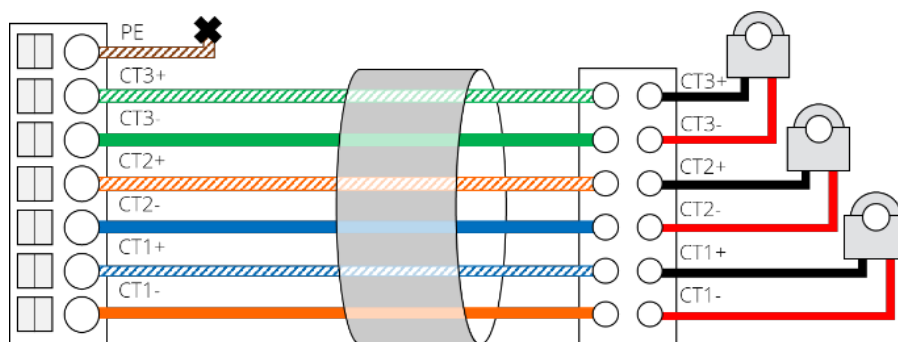
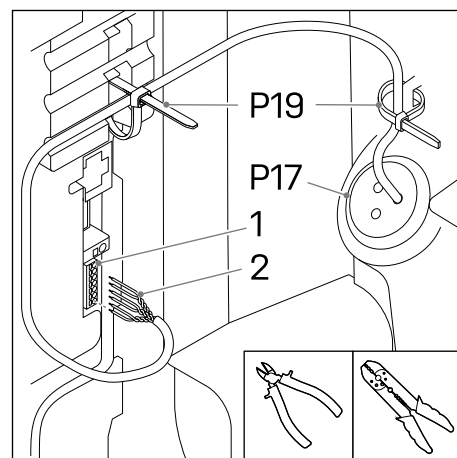

Group load balancing using RS-485*

The group load balancing feature is used when multiple chargers are sharing the same mains connection, i.e., on a parking lot. This feature ensures that the maximum available charge current will not be exceeded, and thus blackouts are prevented. It is recommended to use a shielded Cat-5 or higher cable (only two signal wires per cable will be used). In one group a maximum of 32 chargers can be installed.

- Cut two holes in the grommet placed for peripherals. (In case of the first or last charger in the chain only one hole is needed).
- *Push a cable through the grommet and strip the wires, connect two wires (1) to the BUS connector OUT + and - (2). Forward the cable to the next charger.
- ** Push the cable from the previous charger through the grommet and strip the wires, connect the two wires to the BUS connector IN + and - (2).
- Secure the cables using a cable tie (P19).
- Repeat this step for up to 32 chargers.

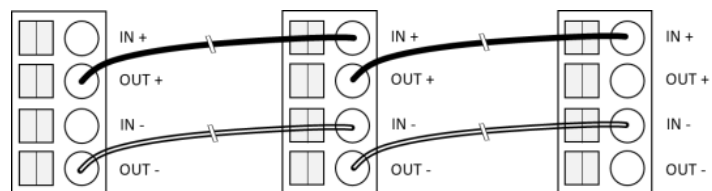
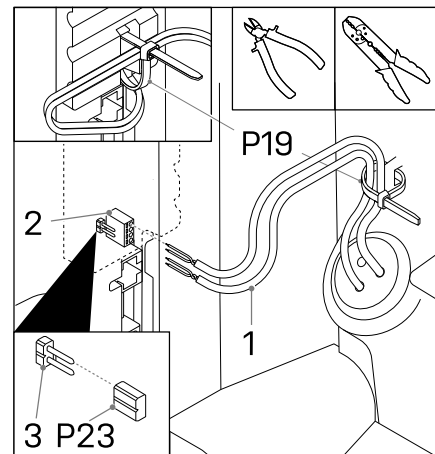

*Not applicable for last charger

**Not applicable for first charger

Attention: Insert the jumper (P23) in the first and last charger in the chain of chargers for termination (3).

During commissioning, make sure that only one charger in the group is configured as 'Leader' all others should be configured as 'Follower'.

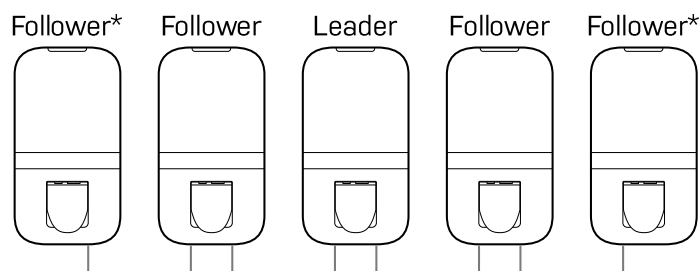

* Insert the jumper in the first and last charger in the chain

SIM card*

- If a SIM card (**P20**) is provided, it can be inserted here. Note that the SIM card might already be installed in its slot.

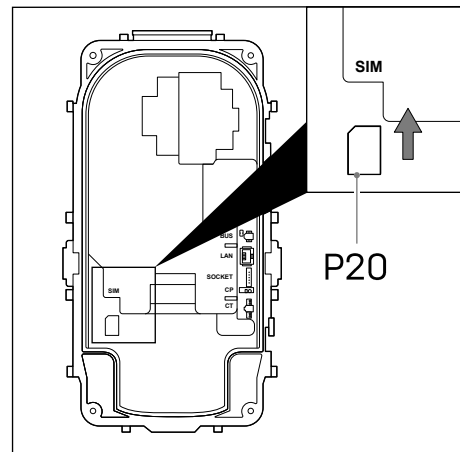

Step 10: Close the box



WARNING: Perform a PE continuity check before closing the box.

Attention: Make sure no water, dirt or foreign objects are present in the charger when closing it.

Attention: Make sure no cables are trapped between the base assembly and the front assembly.

- Connect the connector for the power cables to the front assembly. Press the connector until it clicks.

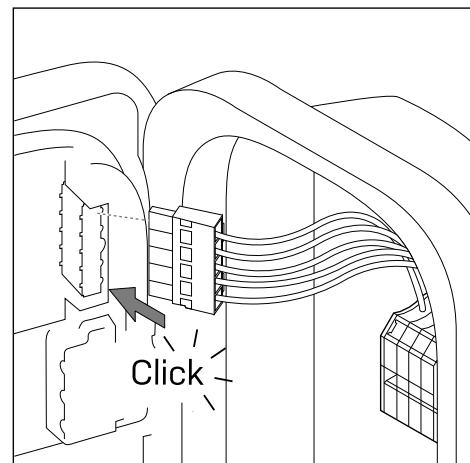

- Close the front assembly.
- Mount the six screws (**P3**) in the order indicated in the figure with 2Nm.

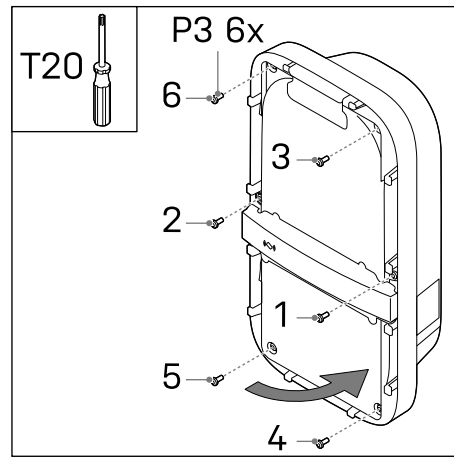

Step 11: Energize

- Turn on the mains connection.

The LED light on the charger should turn yellow first. When it has started up correctly, the status indicator LED should stay yellow. When the status indicator LED turns red, read **Appendix B** for troubleshooting the error.

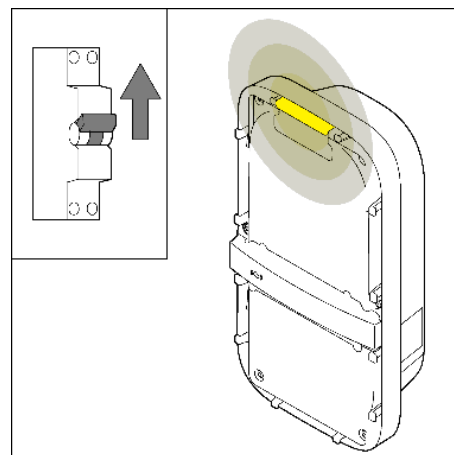

Step 12: Add front covers

Attention: Execute the commissioning in section 2.5 first before placement of the front covers.

- If the charger does not indicate that an error is present after commissioning (red blinking LED), you can attach the front covers of the charger.
- Attach the lower-front cover (**P1**) to the charger.
- Attach the upper-front cover (**P2**) to the charger.
- Make sure both covers are fully clicked around the whole surface.

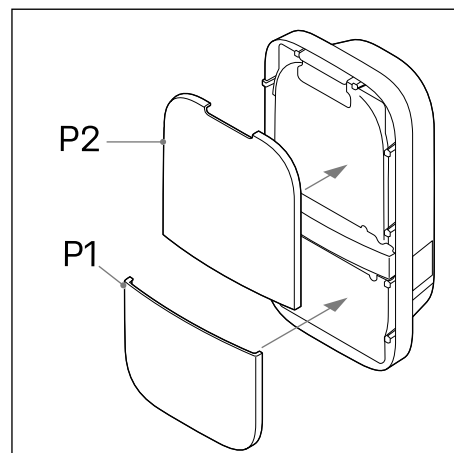

2.5 Commissioning

This section describes the procedure to commission a new, or factory reset, system. First, the access to the web interface is described, followed by the commissioning procedure, and setting of the configuration options.

Access codes

The unique access codes that are required to access and manage the charger through the web interface are located on the label at the back of the manual or quick start guide. The access codes consist of:

WLAN password	The default password to access the WLAN network of the charger in case it acts as an access point.
Default web interface password	The default password to login to the web interface. No username is required, this password is only used by the user as the installation wizard does not require a password. This code can be changed via the web interface.
PUK Code	The code that is required to recover the system in case the web interface password is lost. It must be kept secure by the owner of the system.

Connect with the charger via WLAN

Connect to the WLAN network of the charger. The SSID of the WLAN network hosted by the charger is given on the label in the back of this manual. To gain access to the WLAN network, you can:

- Fill in the credentials manually, provided by the label on the back of the manual or quick start guide.
- Scan the QR code next to the access codes.

Connect with the charger via ethernet*

Connect an ethernet cable to a pc and the charger and follow the next steps to connect with the charger and complete the commissioning procedure.

Access web interface

Once you are connected to the charger, you can access the web interface by opening a browser on your phone or computer. The web interface can also be accessed via the URL or the IP address at the back of the manual or quick start guide.

Commissioning via web interface

Follow the steps in the web interface to successfully complete the commissioning procedure.

After finishing all the steps in the wizard the charger will be rebooted, this takes about one minute. When the commissioning was successful the status LED indicator will turn green. The charger is now ready for use.

2.6 Decommissioning



WARNING: Switch off the mains connection to the charger before starting with this procedure.



WARNING: Only qualified installers must decommission the charger.

- Switch off the mains input power
- Dismount the protective covers (**P1**, **P2**) from the charger.
- Unscrew the six screws (**P3**) from the cover.

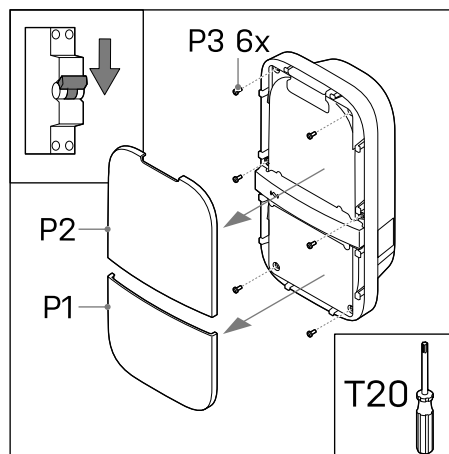

Disconnect the charger from the mains cable:

- Disconnect the peripherals from the front assembly (**2**) and cut all cable ties (**1**).
- Use the push-in connectors at the DIN rail with a flat screwdriver to disconnect the cable ends of the mains cable (**3**).

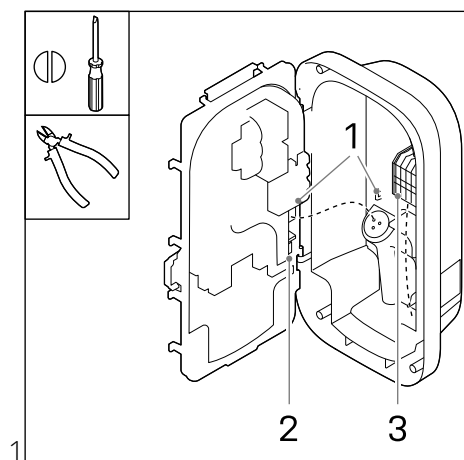

- Unscrew the two lower screws (**P13**) from the base assembly in the charger. Push the charger upwards to safely remove the charger (**P5**) from the wall.
- After removing the charger, remove the mounting hook and keep it near the charger.

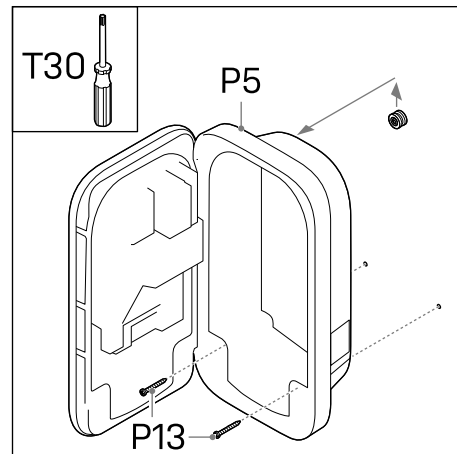

2.7 Transportation, storage

Attention: Transport the charger only when packaged in its original packaging.

Attention: When moving, transporting, or storing the charger, ensure this is done within the charger's allowed temperature and humidity ranges.

2.8 Disposal

Do not dispose this charger in household waste. Instead, dispose this charger at a local collection point for electric/electronic devices to enable recycling and thus avoiding negative and hazardous impacts on the environment. Ask your municipality or local authorities for respective addresses.

Recycling of materials saves raw materials and energy and makes a major contribution to conserving the environment.

Appendix A: Model identification string

To identify the product configurations, the model identification string is used. This string is located on the label on the side of the charger. Use this identification string to determine which configuration options apply to the charger.

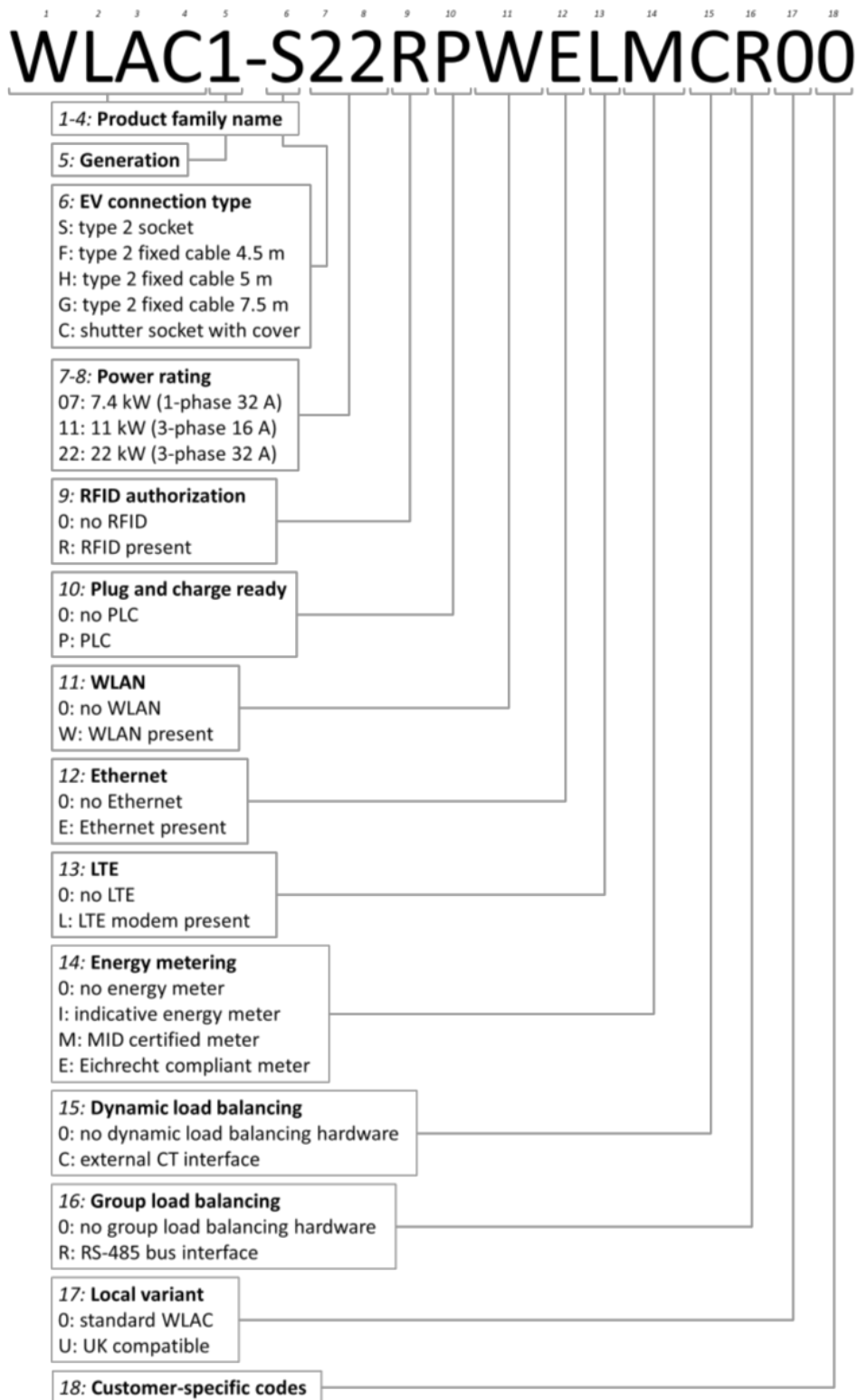

Appendix B: Troubleshooting

When an error is detected, the status indicator LED indicates this with a sequence of flashing red lights. This chapter explains how the user can troubleshoot these errors. The time duration of the flashing lights is 0.5 seconds. Each error bar corresponds with 10 seconds.

Electrical fault

1 red blink 

- This error indicates that the installation has been performed incorrectly or when there is a ground fault. Contact the installer to solve this issue.

Internal fault

2 red blinks 

- Perform a reboot using the web interface. Contact customer support if this issue persists.

EV connection fault

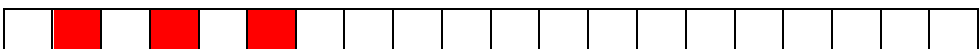
3 red blinks 

- Unplug the charging cable from the vehicle (and charger) and inspect the charging cable and the charging plug for dirt or damage. Contact your customer support or installer if you discover damage.
- If no dirt or damage is found on the charging plug, follow the charging procedure in section 1.4 of the user manual again.
- If the charger still indicates that there is a vehicle connection fault, contact your customer support.

Appendix C: EU - Declaration of conformity

Hereby, Prodrive Technologies B.V. declares that the AC Charger with identifier *WLAC1-XXXXXXXXXXXX* is in compliance with:

- Low-Voltage Directive 2014/35/EU
- Radio Equipment Directive 2014/53/EU
- Electromagnetic Compatibility Directive 2014/30/EU
- RoHS Directive 2011/65/EU
- WEEE2 Directive 2012/19/EU
- REACH Directive 2006/1907/EC



The full text of the EU declaration of conformity is available via the given QR code link or via <http://www.peblar.com/declarations>.

Appendix D: Glossary

Abbreviation	Description
AC	Alternating Current
CP	Control Pilot
CT	Current Transformer
EV	Electric Vehicle
IK	Impact Protection
IP	Ingress Protection
LED	Light Emitting Diode
LTE	Long Term Evolution
NFC	Near-Field Communication
OCPP	Open Charge Point Protocol
PLC	Power Line Communication
PUK	Personal Unblocking Key
RCD	Residual Current Device
RFID	Radio-Frequency Identification
WLAC	White-Label AC Charger
WLAN	Wireless Local Area Network

Unit	Description
A	Ampere
Hz	Hertz
m	meter
mm	millimeter
kW	kiloWatt
kWh	kiloWatt-hour
V	Volt

Prodrive Technologies N.E. hereby excludes all liabilities, warranties, terms and conditions, whether oral or written, express or implied by law, customer or otherwise, including, but not limited to, any warranties, terms and conditions, of fitness for purpose, description, and quality to the maximum extent permitted under applicable law. Prodrive Technologies N.E. have compiled the contents of this document to the best of their knowledge. No express or implied warranty is given for the completeness, accuracy, reliability, or fitness for particular purpose of its content. Specifications and performance data contain average values within existing specification tolerances and are subject to change without prior notice.

Our Products are certified and compliant to the requirements and standards as described in this manual in **Appendix C**.

© 2023 Prodrive Technologies N.E. All rights reserved.

Manufactured by Prodrive Technologies B.V.
Science Park Eindhoven 5501,
5692 EM Son, The Netherlands

