

# Marcel 2xLED GE

140920XX\_140921XX\_140922XX\_140923XX\_140924XX\_140925XX

### CHECK DIP-SWITCHES ON DRIVER

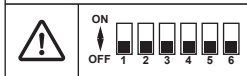

500mA - min 26Vf - max 30,1Vf - 14,1W  
 700mA - min 26,6Vf - max 30,8Vf - 20,1W  
 900mA - min 27Vf - max 31,2Vf - 25,5W  
 1050mA - min 27,3Vf - max 31,7Vf - 31W

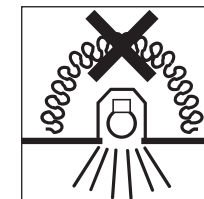
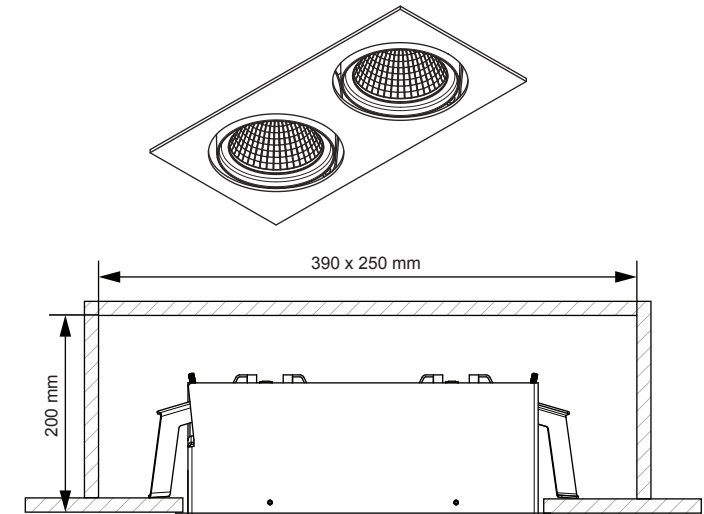
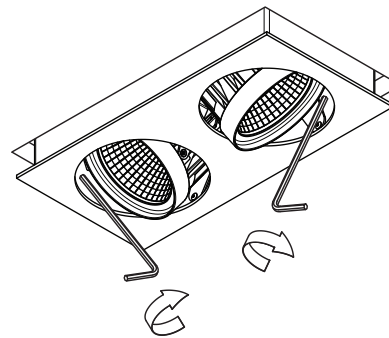
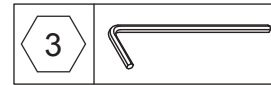
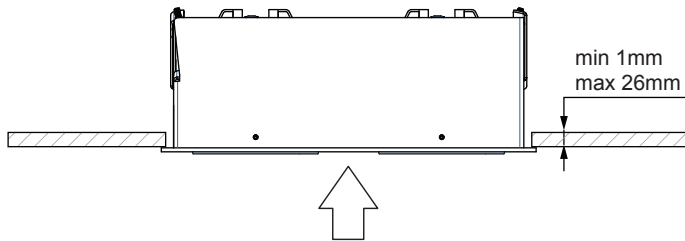
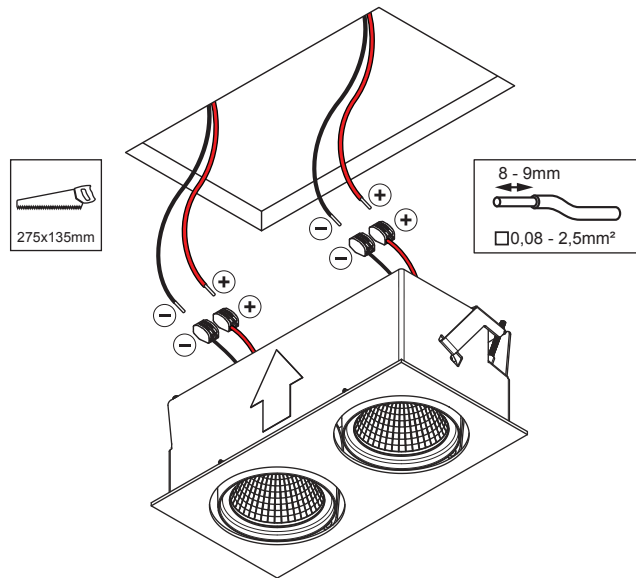

### PREVENTING ELECTROSTATIC DAMAGE

A discharge of static electricity may damage sensitive components. Always be properly grounded when touching leads or circuitry inside the luminaire. Use a wrist strap connected by a ground cord to the housing. Avoid touching the light sources with bare hands.

The light source contained in this luminaire shall only be replaced by the manufacturer or his service agent or a similar qualified person

CAN BE USED WITH  
 Drivers:  
 see driver matrix - latest version on website  
[www.supermodular.com](http://www.supermodular.com) or check sales contact

