

# Smart Dupline® Repeater Type SB2REP230

CARLO GAVAZZI

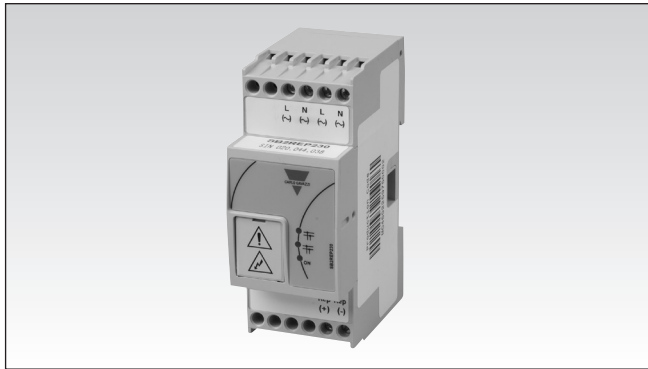

- Smart Dupline® signal repeater
- Regenerates Dupline® signal and boosts power
- Simplifies network design
- Extends the network length in systems with high load
- Isolation between primary and secondary side means primary side not affected by bus short circuit on secondary side
- Automatic restart after removal of short circuit
- Can be used at any point on the Dupline® bus
- 300 mA current drive capability
- For correct operation, SH2MCG24 must be used as primary generator
- 115..240 VAC power supply

## Product Description

SB2REP230 is a 115-240 VAC powered Smart Dupline® repeater and isolator. It is typically used to extend the length of the Dupline® network when the cable resistance and load from bus-powered devices result in an excessive voltage drop. The repeater regenerates the voltage levels of the Dupline® signal and provides an output drive capability of 300 mA. The primary and sec-

ondary Dupline® signals are isolated, which means that the primary side will continue to operate in case of a short circuit on the secondary side. As soon as the short circuit is removed, the secondary side will automatically become operational again within 10 seconds.

The repeater can be connected to any point on the Dupline® bus.

## Ordering Key

**SB2 REP 230**

2-DIN housing  
Repeater  
Power supply

## Type Selection

Power supply	Ordering no.
115..230 VAC	SB2REP230

## Supply Specifications

Rated operational voltage	115..240 VAC
Operational voltage range	115-240 VAC +/-10%
Frequency	45 – 65 Hz
Overvoltage category	II (IEC 60664-1, par. 4.3.3.2)
Rated impulse voltage	500V (1,2/50µs) (IEC 60664-1, tab. F.1)
Rated operational power	10 VA
<b>Dielectric voltage</b>	
Supply - primary Dupline®	> 4 kVAC
Supply - secondary Dupline®	> 4 kVAC
Primary Dupline® - secondary Dupline®	> 4 kVAC
<b>Power ON delay</b>	Typ. 10 s
<b>Power OFF delay</b>	< 1 s

## Dupline® Specifications

Output voltage	8.2 VDC
Max bus voltage	10.0 VDC
Max Dupline® current load	300 mA
<b>Terminal</b>	Sec Sec Dup+ Dup-



## General Specifications

<b>Environment</b>	
Pollution degree	2 (IEC 60664-1, par. 4.6.2)
Operating temperature	0° to +50°C (32° to 122°F)
Operating temperature cURus	0° to +40°C (32° to 104°F)
Storage temperature	-50° to +85°C (-58° to 185°F)
Humidity	20 to 90% (non-condensing)
<b>Connection</b>	
Terminal	6 screw-type
Cable cross-section area	max. 1.5 mm <sup>2</sup>
Tightening torque	0.8 Nm
<b>Housing</b>	
Material	NORYL
Dimensions	2 DIN module
Weight	110 g
<b>Approvals</b>	cURus

<b>CE Marking</b>	Yes
<b>EMC</b>	
Immunity	EN 61000-6-2
- Electrostatic discharge	EN 61000-4-2
- Radiated radiofrequency	EN 61000-4-3
- Burst immunity	EN 61000-4-4
- Surge	EN 61000-4-5
- Conducted radio frequency	EN 61000-4-6
- Power frequency magnetic fields	EN 61000-4-8
- Voltage dips, variations, interruptions	EN 61000-4-11
Emission	EN 61000-6-3
- Conducted and radiated emissions	
- Conducted emissions	CISPR 22 (EN55022), cl. B
- Radiated emissions	CISPR 16-2-1 (EN55016-2-1) CISPR 16-2-3 (EN55016-2-3)

## Mode of Operation

SB2REP230 is a 115-240 VAC powered Smart Dupline® repeater and isolator. On one side, it has an input for the primary Dupline® bus generated by SH2MCG24, and on the other side, it has a secondary bus output with the regenerated Dupline® carrier signal. When calculating the load and cable voltage drop, the secondary Dupline® is to be considered the starting point of a new bus with a 300 mA load capability and full signal voltage. If e.g. a repeater is

inserted in the middle of a bus line with uniform load distribution, cable resistance and bus load will be reduced by half for each of the two segments compared to the single line. Thereby, distance capability is increased by a factor of 4. For further information regarding transmission distance calculations, please refer to the SxWEB HW manual. It is allowed to connect multiple repeaters to the same primary Dupline®, but it is

not allowed to use the secondary output of one repeater as primary input of another one (in other words, cascading of repeaters is not allowed).

The primary and secondary buses are galvanically isolated from each other, which means that the primary bus continues to operate in case of a short circuit on the secondary bus. Hence the repeater can be used to protect an installation against short circuits. As soon as a

short circuit is removed, the secondary bus will automatically start up within 10 seconds.

**Note 1:** The adapter SH1DUPFT is required for the primary bus connection.

**Note 2:** For correct operation, SH2MCG24 must be used as the primary generator.

**Note 3 for cURus:** A readily accessible disconnect device must be incorporated in the building installation wiring.

## Settings and LED Indication

<b>Power LED (green)</b>	ON OFF	Supply ON Supply OFF
<b>STATUS LED (yellow)</b>	ON OFF	Primary Dup OK Not present/error
<b>STATUS LED (yellow)</b>	ON 1 blink 2 blinks 3 blinks 4 blinks 5 blinks	Secondary Dup OK Wrong connection Short circuit Overcurrent Critical overcurrent HW error

## Wiring Diagram

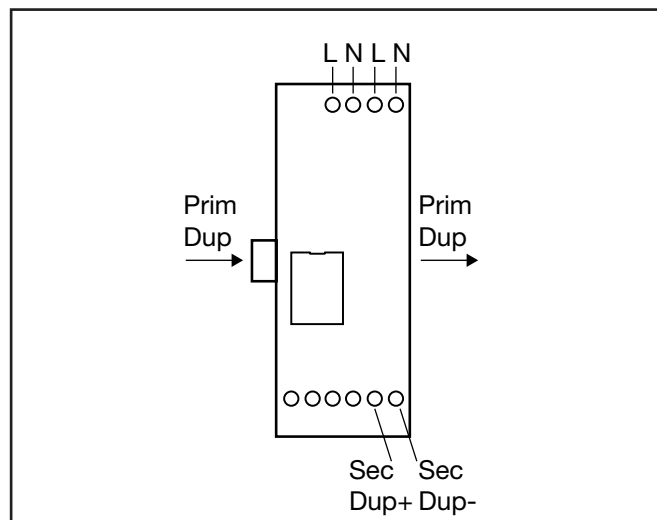

## System Diagram

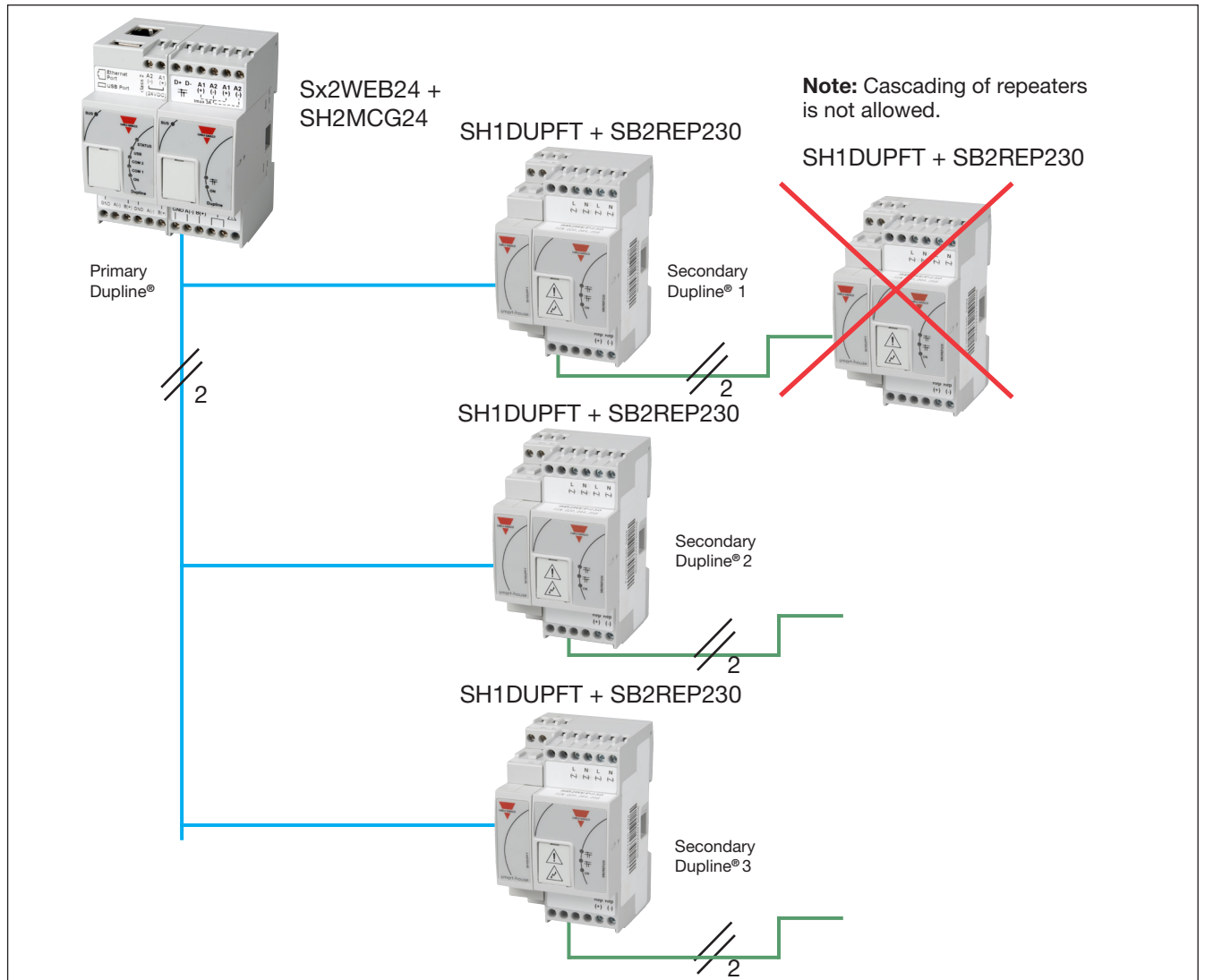

## Dimensions

