

Flat moon suspension 450 up down LED

133006XX_133007XX_133008XX_133009XX_133010XX_133011XX

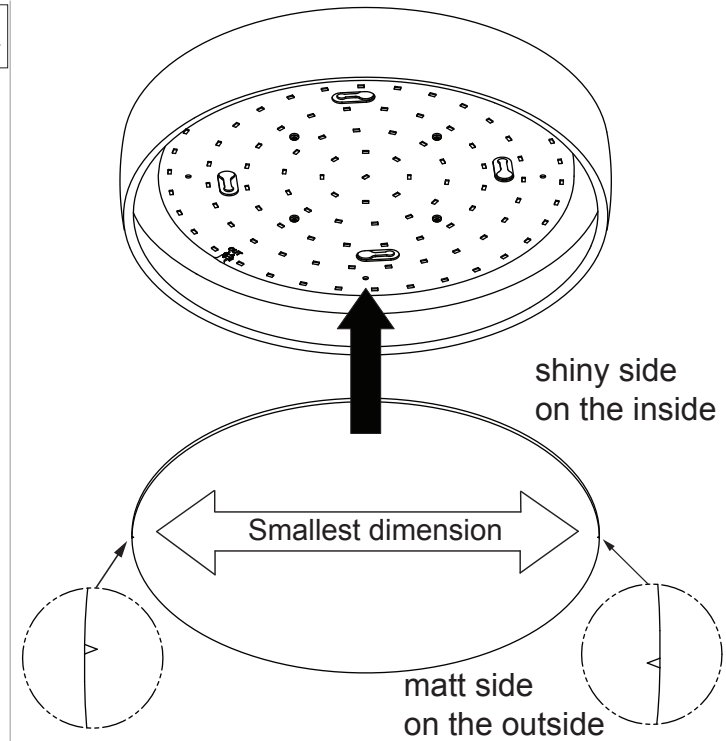

Replace protective shield when broken. The luminaire shall only be used complete with its protective shield. Reference number: down = 1012134 / up = 1012247

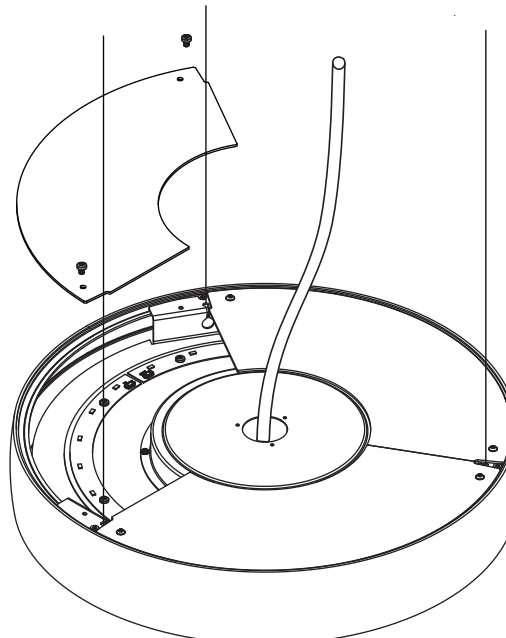
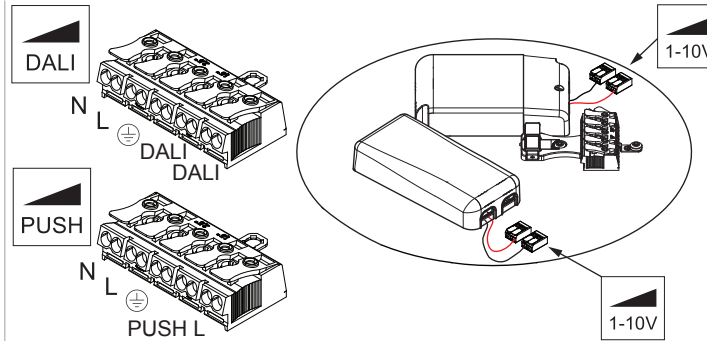
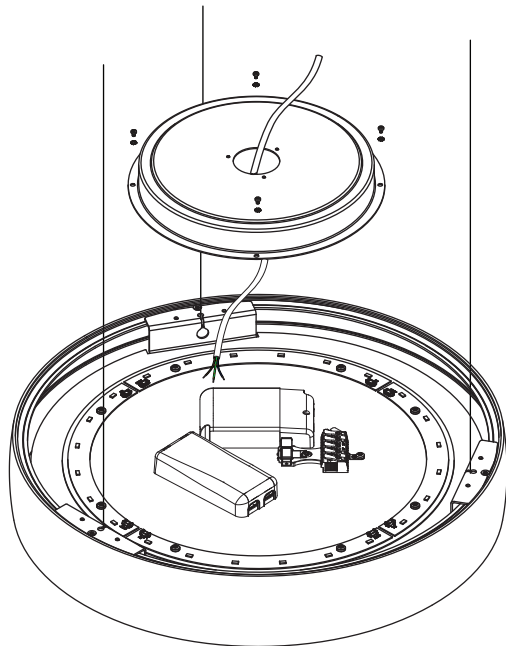
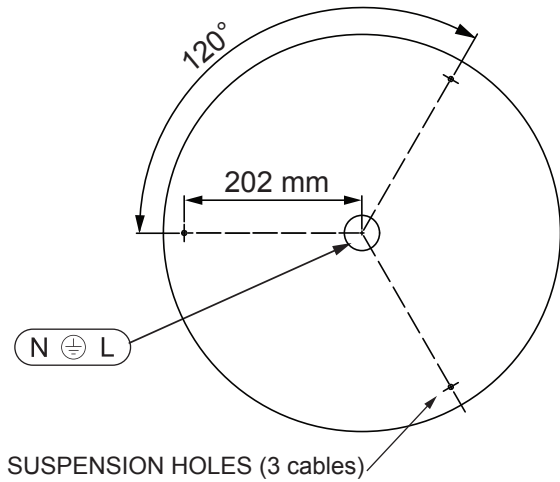

The light source contained in this luminaire shall only be replaced by the manufacturer or his service agent or a similar qualified person

CAN BE USED WITH

Susp kit non dimmable

- 11061809 Suspension kit 4m 3x0,75 (3 cables) - WhStr
- 11061832 Suspension kit 4m 3x0,75 (3 cables) BlStr
- 11062009 Susp kit 1 4m 3x0,75 3tri cables WhStr
- 11062032 Susp kit 1 4m 3x0,75 3tri cables BlStr

Susp kit dimmable

- 11061909 Suspension kit 4m 5x0,75 (3cables) Whstr
- 11061932 Suspension kit 4m 5x0,75 (3cables) Blstr
- 11062109 Susp kit 1 4m 5x0,75 3tri cables WhStr
- 11062132 Susp kit 1 4m 5x0,75 3tri cables BlStr
- 11062409 Suspension kit 4m 9x0,75 (3cables) whstr
- 11062432 Suspension kit 4m 9x0,75 (3cables) Blstr
- 11062509 Susp kit 1 4m 9x0,75 3tri cables WhStr
- 11062532 Susp kit 1 4m 9x0,75 3tri cables BlStr

Prismatic diffuser

- 13289000 FlatMn prismatic diffuser 450/470
- 13289100 FlatMn ice prismatic diffuser 450/470

