



USER MANUAL

P1MB

P1 Modbus converter

Copyright © XEMEX

All rights reserved. No part of this publication may be reproduced, stored in a retrieval system, or transmitted, in any form or by any means, electronic, mechanical, photocopying, recording or otherwise, without prior written permission of the publisher.

E info@xemex.eu
T +32 (0)3 201 95 95
F +32 (0)3 201 95 99
W www.xemex.eu

NL Burgemeester Burgerslaan 40
5245 NH 's-Hertogenbosch
BE Metropoolstraat 11a
B2900 Schoten

BTW 0458.522.364
OND. NR. 458.522.364
IBAN BE56 1735 0211 4388
BIC-SWIFT RABO NL2U

DOCUMENT INFO

Version: 1.6
Status: Draft
Version date: 5/04/2023
Filename: User manual - P1MB.docx
Number of pages: 18

HISTORY CHANGES

VERSION	DATE	DESCRIPTION
1.0	22/06/21	Initial version
1.1	21/10/21	Clarification for Total E forward / reverse modbus value
1.2	20/07/22	Modbus memory map correction (Tariff indicator) and P1 version explanation
1.3	25/07/22	Modbus memory map correction (P1 version)
1.4	04/08/22	Termination resistor not assembled by default
1.5	20/01/23	Modbus memory map correction (Register length for Currents is 1)
1.6	04/04/23	Decommissioning and Disposal

TABLE OF CONTENTS

1	INTRODUCTION.....	5
1.1	Scope	5
1.2	Target group	5
1.3	Intended usage	5
1.4	Technical assistance.....	5
1.5	Used symbols.....	6
1.6	Safety precautions:.....	6
2	TECHNICAL DESCRIPTION	7
2.1	General description	7
2.2	Use Cases	8
2.2.1	NOM Monitoring application	8
2.2.2	EV Charging Station	8
3	TECHNICAL SPECIFICATIONS	9
3.1	Form factor	9
3.2	Environmental conditions.....	9
3.3	DC Power Interface (optional)	9
3.4	P1 Interface	9
3.5	P1 Cable Specifications	10
3.6	Modbus Interface	10
3.7	Modbus Cable Specifications.....	10
3.8	User Interface	10
3.8.1	Power indicator LED	10
3.8.2	P1 port indicator.....	11
3.8.3	Modbus indicator LED	11
3.9	Screw terminals	11
3.10	Modbus Properties	11
3.10.1	Physical LAYER properties.....	11
3.10.2	Data Link LAYER properties.....	12
3.10.3	Application LAYER properties	12
3.11	Modbus registers.....	12
4	INSTALLATION INSTRUCTIONS	15
4.1	Guidelines for safety and installation	15
4.2	Mounting	15
4.3	Electrical wiring	15
4.4	Wire stripping	15
4.5	NOTES	16
5	OPERATING INSTRUCTIONS	17
5.1	PWR - POWER Status LED – Yellow LED.....	17
5.2	P1 – P1 Status LED – Green LED.....	17

- 5.3 MB – Modbus Status LED – Red LED..... 17

- 6 CLEANING.....18**

- 7 LIFTING AND CARRYING18**

- 8 MAINTENANCE AND SERVICE18**

- 9 DECOMMISSIONING AND DISPOSAL18**
 - 9.1 Decommissioning..... 18
 - 9.2 Disposal..... 18

1 Introduction

1.1 Scope

This manual is applicable to P1MB, a device which interfaces to the P1 port of a smart meter and transforms the data and make it available on its Modbus slave interface to be read out via a Modbus RTU.

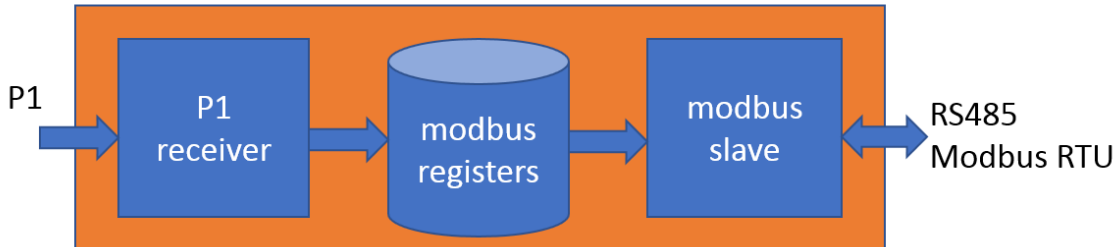

This document describes the specifications, installation and operation of the product. Please read this document carefully before installation and operating.

1.2 Target group

The installation and the operation of this device and any maintenance must be carried out by a qualified person in accordance with specific local standards and safety regulations.

1.3 Intended usage

The P1MB is only to be used for in combination with a smart meter with P1 output and shall operate within the specified values only.

1.4 Technical assistance





In case technical assistance is needed, contact Xemex NV:

XEMEX NV
Metropoolstraat 11a
B-2900 Schoten
Belgium

Tel: +32 201 95 95
E-mail: support@xemex.eu

1.5 Used symbols

Following symbols are used in this document and/or are marked on the product:

	Alternating current
	Three-phase alternating current
	Equipment protected throughout by DOUBLE INSULATION or REINFORCED INSULATION
	Caution, possibility of electric shock
	Caution

1.6 Safety precautions:

Always adhere to the following checklist:

1. Only qualified personnel or licensed electricians should install the Xemex P1MB.
2. Follow all applicable local and national electrical and safety codes.
3. Install the P1MB device in an electrical enclosure (panel or junction box) or in a limited access electrical room.
4. Before applying power, check that all the wires are securely installed by tugging on each wire.
5. Do not install the P1MB where it may be exposed to temperatures below -25°C or above 75°C , excessive moisture, dust, salt spray, or other contamination. The device requires an environment no worse than pollution degree 2 (normally only non-conductive pollution; occasionally, a temporary conductivity caused by condensation must be expected).
6. Do not drill mounting holes in the device. Click the module on a DIN Rail instead.
7. If the P1MB is installed incorrectly, the safety protections may be impaired.

2 Technical description

2.1 General description

The Xemex P1MB device is a device which interfaces to the P1 port of a smart meter and transforms the data and make it available on its Modbus slave interface.

It has following interfaces:

- +5V DC Power Interface
- User Interface
- P1 Interface
- RS485 Communication Interface (Modbus slave)

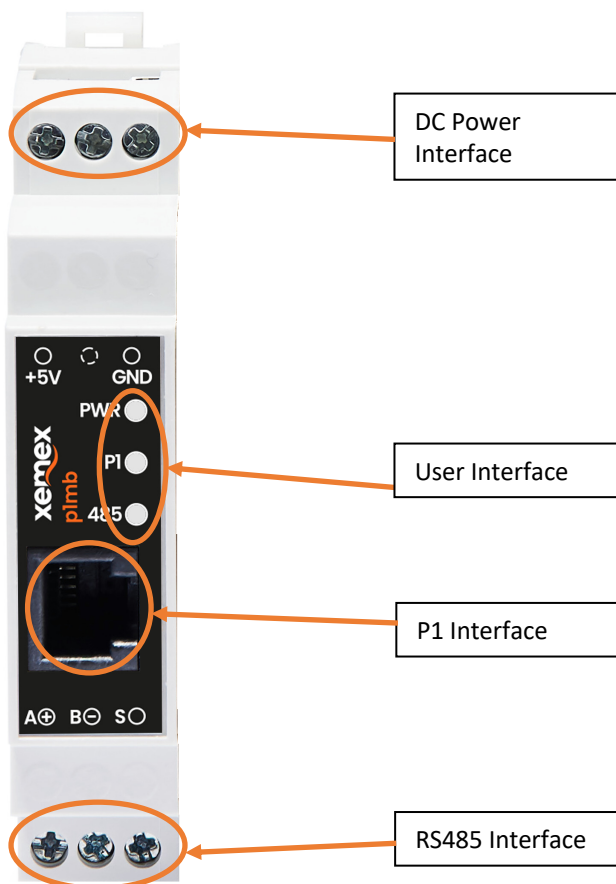

The P1MB is connected via an RJ12 connection to the P1 port of a smart meter. The device is powered by the +5V of the P1 port of the connected smart meter. If not available the P1MB can optionally be powered by an external adapter connected to the DC power interface.

The P1MB enables the request line of the P1 port and captures every second the P1 data in its Modbus memory map. The P1MB acts as a Modbus slave and can be read out by a Modbus RTU master connected to the RS485 interface.

2.2 Use Cases

Some examples of P1MB uses cases:

2.2.1 NOM Monitoring application

In a “Null-Op-de-Meter” monitoring application, one of the measured items is the Total E-energy Consumption. This value can be acquired via different means: via ODA/P4, via an extra E-meter for Total E-energy Consumption or via the P1 interface of an existing smart meter. In the latter case, the P1MB device can be used to make the NOM Total E-energy Consumption available for the DNG MON data collector.

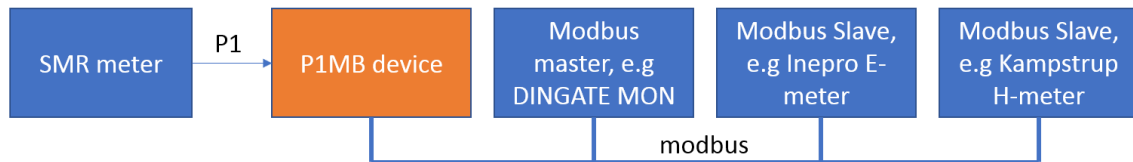

2.2.2 EV Charging Station

In order to charge an electrical vehicle as quickly as possible, a residential charging station needs to know how much power of the total available grid connection is in use by the household appliances and how much is available for charging. Using the P1MB device, the charging station can get this information through a Modbus interface from a smart meter.

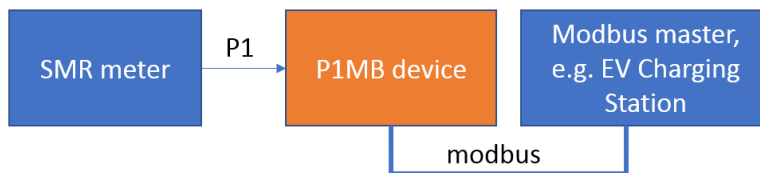

3 Technical specifications

3.1 Form factor

Housing	DIN 43880 / 1 unit
Dimensions	90 x 18 x 65mm

3.2 Environmental conditions

Protection class	II
Operating temperature	-25 °C - +75 °C
Storage temperature	-40 °C - +85 °C
Relative humidity	< 75 % year's average at 21 °C < 95 % less than 30 days/year, at 25 °C
Pollution Degree	2
Altitude	< 2000m
Application area	Residential, Indoors in suitable meter cabinet

3.3 DC Power Interface (optional)



WARNING

Only use the DC power interface if the P1MB is not powered via the P1 port of the smart meter. See also cable specification 3.4



DANGER

Use SELV power supply only!
Risk of serious injuries or death and/or at least product damage!

Connector	Screw terminal connector for 0V and +5V DC
Voltage range:	5V DC, -10%, +10%
Max current consumption:	50 mA
Max cable length:	3 meter
Cable location:	indoor + outdoor
Reverse polarity protection:	yes

3.4 P1 Interface

Protocol	P1 protocol conform DSMR4/DSMR5 (NL) and eMUCS (BE)
Max cable length:	3 meter
Cable location:	indoor
Connector	RJ12 – 6 pin
Pin definition	

Pin #	Signal name	Description	Remark
1	+5V	+5V power supply	Power input for P1MB device
2	Data Request	Data Request	Output for P1MB device
3	Data GND	Data ground	
4	n.c.	Not connected	
5	Data	Data line	Input . Current source PU.
6	Power GND	Power ground	

3.5 P1 Cable Specifications

Use a 4-wire or 6-wire cable depending if you use the +5V of the smart meter or not. On one end the cable should be foreseen with a RJ11 or RJ12 connector.



Warning

A 4-wire cable will not connect to the +5V of the smart meter. So you can only use a 4-wire cable in combination with the +5V power adapter!

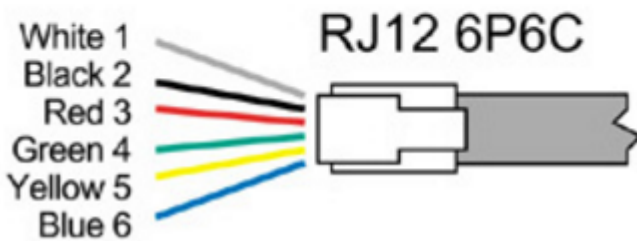

3.6 Modbus Interface

Connector	Screw terminal connector for A, B and Shield
Bus termination	120 Ohm, switchable on/off
Protocol	Modbus RTU over RS485
Max cable length:	100 meter
Cable location:	indoor + outdoor

3.7 Modbus Cable Specifications

Preferably armored twisted pair with drain wire. Section 0,20 ... 0,50 mm².

Example of cable type: Belden 3107A

3.8 User Interface

3.8.1 Power indicator LED

The PWR LED is a yellow LED that will light up from the moment the P1MB device gets power.

If after installation, the LED doesn't light up you should check the connection with the smart meter or the mains power if you use a power adapter.

3.8.2 P1 port indicator

The P1 port indicator LED is a green LED that will light up if a correct P1 message is received from the smart meter. For this it is necessary that the P1MB device is connected to the smart meter.

3.8.3 Modbus indicator LED

The Modbus indicator LED is a red LED that gives an indication that the P1MB device has received a read request from a Modbus RTU master.

3.9 Screw terminals

Single-deck terminal block - Right side - Pitch 5mm - 3 poles

GENERAL INFORMATION

pitch:	5 mm
housing height:	15,30 mm
housing depth:	9.5 mm
dimensional class:	medium
wire section:	2.5 mm ² / 14 AWG
clamp opening size:	2.7 × 2.7 mm
wire stripping:	max 7 mm
operating temperature:	-40°C + +130°C

ELECTRICAL CHARACTERISTICS

current:	16A
voltage:	250V
test voltage:	2 kVrms/60s

MECHANICAL CHARACTERISTICS

screw:	M3
max. torque:	0.5 Nm / 4.5 in.lbs

APPROVALS DATA



	EN 60998-1	-	UL 1059
current:	16A	-	15A factory / 15A field
voltage:	250V	-	300V
wire section:	2.5mm ²	-	14+30AWG
torque:	0.5Nm	-	4.5Lb-in
FILE:	CA02.01614	-	E178356

MATERIALS

housing:	PA - UL 94 V0
screw:	Galvanized steel
clamp/spring:	Nickel copper alloy
terminal:	Tin-plated copper alloy

AVAILABLE COLOURS

GN	GY (STD)	BK	BL	RD	YL	OG
other colours:						upon request

3.10 Modbus Properties

3.10.1 Physical LAYER properties

- Baud rate:
 - 1200 ... 115200
 - default value is **9600 baud**.
- Line setting:
 - Available options
 - 8 Data bits, no parity, 1 stop bit = 8N1 (line settings register value = 0x04) ,
 - 8 Data bits, even parity, 1 stop bit = 8E1 (line settings register value = 0x24)
 - default value is **8E1**.
- P1MB can be equipped with a line termination resistor:

- default **no termination resistor assembled**.
- Special tooling is needed to change the physical layer parameters. This is done during the production of the device. So if you need different settings, please specify with the order.

3.10.2 Data Link LAYER properties

- Modbus device address
 - Range: 1 .. 247
 - Default address is **16**
 - The Modbus address can be configured via the Modbus connection

3.10.3 Application LAYER properties

Modbus RTU server which supports following Modbus Function Codes:

- Read Holding Register
- Write Single Register

3.11 Modbus registers

The registers below are accessible by the Modbus function code 03 – *Read Holding Register*.

The registers marked in **orange** can also be written by the Modbus function 06 – Write Single Register.

Updated settings become active after rebooting the device by writing the Reboot register.

Reg address	Register length (# of u16)	Contents	P1 msg source	Data type
0	8	LDN	N.A.	HEX
8	3	Manufacturer	N.A.	HEX
11	8	FW version	N.A.	HEX
19	1	Modbus device address	N.A.	UINT16
20	48	P1 msg header	P1 msg header	HEX
68	2	Version information for P1 output ⁽²⁾	1-3:0.2.8	HEX
70	7	P1 msg timestamp	0-0:1.0.0	HEX
77	1	RFU	N.A.	N.A.
78	48	Equipment ID	0-0:96.1.1	HEX
126	2	E-forward T1 - Value	1-0:1.8.1	UINT32
128	2	E-forward T2 - Value	1-0:1.8.2	UINT32
130	2	E-reverse T1 - Value	1-0:2.8.1	UINT32
132	2	E-reverse T2 - Value	1-0:2.8.2	UINT32
134	2	Tariff indicator	0-0:96.14.0	HEX
136	2	P-forward - Value	1-0:1.7.0	UINT32
138	2	P-reverse - Value	1-0:2.7.0	UINT32
140	2	Number of power failures in any phase	0-0:96.7.21	UINT32
142	2	Number of long power failures in any phase	0-0:96.7.9	UINT32
144	2	Power Failure Event Log – Nb of entries	1-0:99.97.0	UINT32
146	7	Power Failure Event Log – timestamp[0]	1-0:99.97.0	HEX

153	2	Power Failure Event Log – duration[0]	1-0:99.97.0	UINT32
155	7	Power Failure Event Log – timestamp[1]	1-0:99.97.0	HEX
162	2	Power Failure Event Log – duration[1]	1-0:99.97.0	UINT32
164	7	Power Failure Event Log – timestamp[2]	1-0:99.97.0	HEX
171	2	Power Failure Event Log – duration[2]	1-0:99.97.0	UINT32
173	7	Power Failure Event Log – timestamp[3]	1-0:99.97.0	HEX
180	2	Power Failure Event Log – duration[3]	1-0:99.97.0	UINT32
182	7	Power Failure Event Log – timestamp[4]	1-0:99.97.0	HEX
189	2	Power Failure Event Log – duration[4]	1-0:99.97.0	UINT32
191	7	Power Failure Event Log – timestamp[5]	1-0:99.97.0	HEX
198	2	Power Failure Event Log – duration[5]	1-0:99.97.0	UINT32
200	7	Power Failure Event Log – timestamp[6]	1-0:99.97.0	HEX
207	2	Power Failure Event Log – duration[6]	1-0:99.97.0	UINT32
209	7	Power Failure Event Log – timestamp[7]	1-0:99.97.0	HEX
216	2	Power Failure Event Log – duration[7]	1-0:99.97.0	UINT32
218	7	Power Failure Event Log – timestamp[8]	1-0:99.97.0	HEX
225	2	Power Failure Event Log – duration[8]	1-0:99.97.0	UINT32
227	7	Power Failure Event Log – timestamp[9]	1-0:99.97.0	HEX
234	2	Power Failure Event Log – duration[9]	1-0:99.97.0	UINT32
236	2	Number of voltage sags in phase L1	1-0:32.32.0	UINT32
238	2	Number of voltage sags in phase L2	1-0:52.32.0	UINT33
240	2	Number of voltage sags in phase L3	1-0:72.32.0	UINT32
242	2	Number of voltage swells in phase L1	1-0:32.36.0	UINT32
244	2	Number of voltage swells in phase L2	1-0:52.36.0	UINT32
246	2	Number of voltage swells in phase L3	1-0:72.36.0	UINT32
248	1	Text Message Length	0-0:96.13.0	UINT16
249	512	Text message	0-0:96.13.0	HEX
761	2	Instantaneous voltage L1 - Value	1-0:32.7.0	UINT32
763	2	Instantaneous voltage L2 - Value	1-0:52.7.0	UINT32
765	2	Instantaneous voltage L3 - Value	1-0:72.7.0	UINT32
767	1	Instantaneous current L1 – Value	1-0:31.7.0	UINT16
769	1	Instantaneous current L2 – Value	1-0:51.7.0	UINT16
771	1	Instantaneous current L3 - Value	1-0:71.7.0	UINT16
773	2	Instantaneous active power (+P) L1 - Value	1-0:21.7.0	UINT32
775	2	Instantaneous active power (+P) L2 - Value	1-0:41.7.0	UINT32
777	2	Instantaneous active power (+P) L3 - Value	1-0:61.7.0	UINT32
779	2	Instantaneous active power (-P) L1 - Value	1-0:22.7.0	UINT32
781	2	Instantaneous active power (-P) L2 - Value	1-0:42.7.0	UINT32
783	2	Instantaneous active power (-P) L3 - Value	1-0:62.7.0	UINT32
785	1	Device Type – M bus channel 1	0-1:24.1.0	UINT16
786	1	Device Type – M bus channel 2	0-2:24.1.0	UINT16

787	1	Device Type – M bus channel 3	0-3:24.1.0	UINT16
788	1	Device Type – M bus channel 4	0-4:24.1.0	UINT16
789	48	Equipment ID – M bus channel 1	0-1:96.1.0	HEX
837	48	Equipment ID – M bus channel 2	0-2:96.1.0	HEX
885	48	Equipment ID – M bus channel 3	0-3:96.1.0	HEX
933	48	Equipment ID – M bus channel 4	0-4:96.1.0	HEX
981	7	Last 5 min reading – timestamp – M bus channel 1	0-1:24.2.1	HEX
988	2	Last 5 min reading – value – M bus channel 1	0-1:24.2.1	UINT32
990	7	Last 5 min reading – timestamp – M bus channel 2	0-2:24.2.1	HEX
997	2	Last 5 min reading – value – M bus channel 2	0-2:24.2.1	UINT32
999	7	Last 5 min reading – timestamp – M bus channel 3	0-3:24.2.1	HEX
1006	2	Last 5 min reading – value – M bus channel 3	0-3:24.2.1	UINT32
1008	7	Last 5 min reading – timestamp – M bus channel 4	0-4:24.2.1	HEX
1015	2	Last 5 min reading – value – M bus channel 4	0-4:24.2.1	UINT32
1017	2	E-FORWARD total value ⁽¹⁾	1-0:1.8.1	UINT32
			1-0:1.8.2	
1019	2	E-REVERSE total value ⁽¹⁾	1-0:2.8.1	UINT32
			1-0:2.8.2	
1021	4	P1 Version Info ⁽²⁾	0-0:96.1.4	HEX
1025	1	E-Breaker State	0-0:96.3.10	HEX
1026	2	E-Limiter Threshold	0-0:17.0.0	UINT32
1028	1	Fuse Supervision Threshold	1-0:34.4.0	UINT16
1029	1	M-Bus Valve State Channel 1	0-1:24.4.0	UINT16
1030	1	M-Bus Valve State Channel 2	0-2:24.4.0	UINT16
1031	1	M-Bus Valve State Channel 3	0-3:24.4.0	UINT16
1032	1	M-Bus Valve State Channel 4	0-4:24.4.0	UINT16

⁽¹⁾ Value is sum of P1 msg source

⁽²⁾ There is a different P1 version object for DSMR (NL) and eMUCS (BE)

4 Installation instructions

4.1 Guidelines for safety and installation



This installation guide must be consulted in all cases when manipulating parts which are marked with the Caution symbol.

The installation and the operation of this device and any maintenance must be carried out by a qualified person in accordance with specific local standards and safety regulations.

Failing to obey the "Guidelines for safety and installation", the guarantee no longer applies.

4.2 Mounting

Mount the device in a DIN rail cabinet.

4.3 Electrical wiring

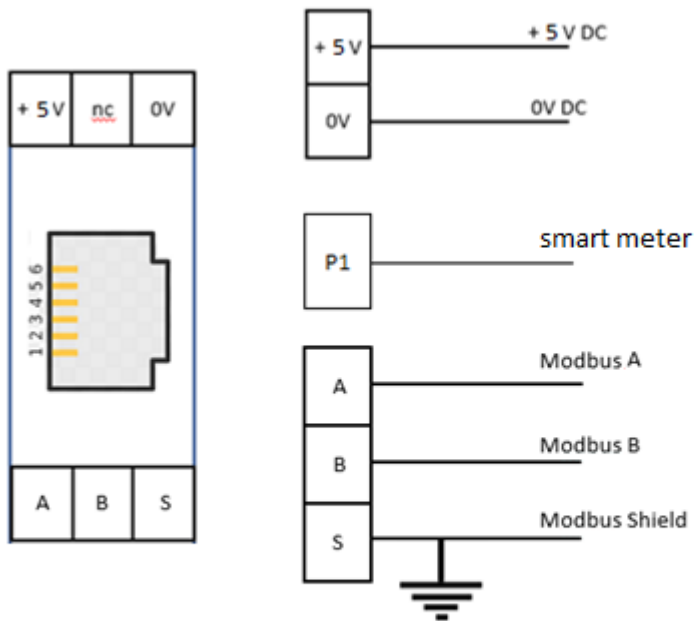

4.4 Wire stripping

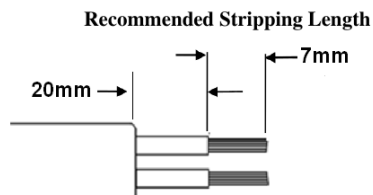

4.5 NOTES



The Modbus Shield must only be connected at the P1MB side and not at the Modbus master side. The Modbus Shield connection is also connected to the protected earth of the building.

5 Operating instructions

After installation and applying DC power the device starts automatically and puts its request line high to get a P1 message from the smart meter. The P1 message is converted and stored in the defined Modbus registers.

A connected Modbus master can request these values by reading the corresponding Modbus registers.

The P1MB device gives visual feedback by its 3 Status Indicators:

5.1 PWR - POWER Status LED – Yellow LED

- Not lit: P1MB device is not powered
- Lit: P1MB device is powered

5.2 P1 – P1 Status LED – Green LED

- Not lit no valid P1 data received from the smart meter within the last minute
- Lit: P1 data received with correct CRC

5.3 MB – Modbus Status LED – Red LED

- Not lit: no data received within the last 6 minutes.
- Blinking: data received, but no valid* Modbus request received within the last minute
- Continuously lit: valid* Modbus request received within the last minute

Valid* = CRC verified frame for own address

6 Cleaning

Clean the unit with a slightly damp cloth and mild detergent.

7 Lifting and carrying

Use care when lifting and carrying the product.

8 Maintenance and Service

There are no serviceable parts inside.

9 Decommissioning and Disposal

This section explains the disconnection of the P1MB from the system and its correct disposal.

9.1 Decommissioning

The decommissioning must be carried out by a qualified person in accordance with specific local standards and safety regulations.

Remove the P1MB as follows:

1. Switch off the voltage of the P1MB by disconnecting the P1 port cable on the P1 interface and, if installed, disconnect the external adapter connected to the DC power interface. The yellow Power status LED (PWR) turns off.
2. Remove the connecting wires of the Modbus RTU master connected to the RS485 interface.
3. Use a flat-tip screwdriver (≤ 6.5 mm / 0.25 in) to lower the locking mechanism and release the meter from the DINrail.

9.2 Disposal

For disposal of the P1MB, observe the local disposal and environmental protection regulations in effect without fail.

Components	Disposal
Circuit boards	Electronical waste: disposal according to local regulations
Metal parts	Sorted and taken to collective materials disposal point
Plastic components	Sorted and taken to recycling (regranulation) plant

End Of Document.